

I'm *COMUTA-CAR*

I've got the solution for stopping pollution.
Help fight inflation! Stay out of the station!
Drive with a smile for a few cents a mile.
Not going far? Drive COMUTA-CAR!

Call: 367-7473

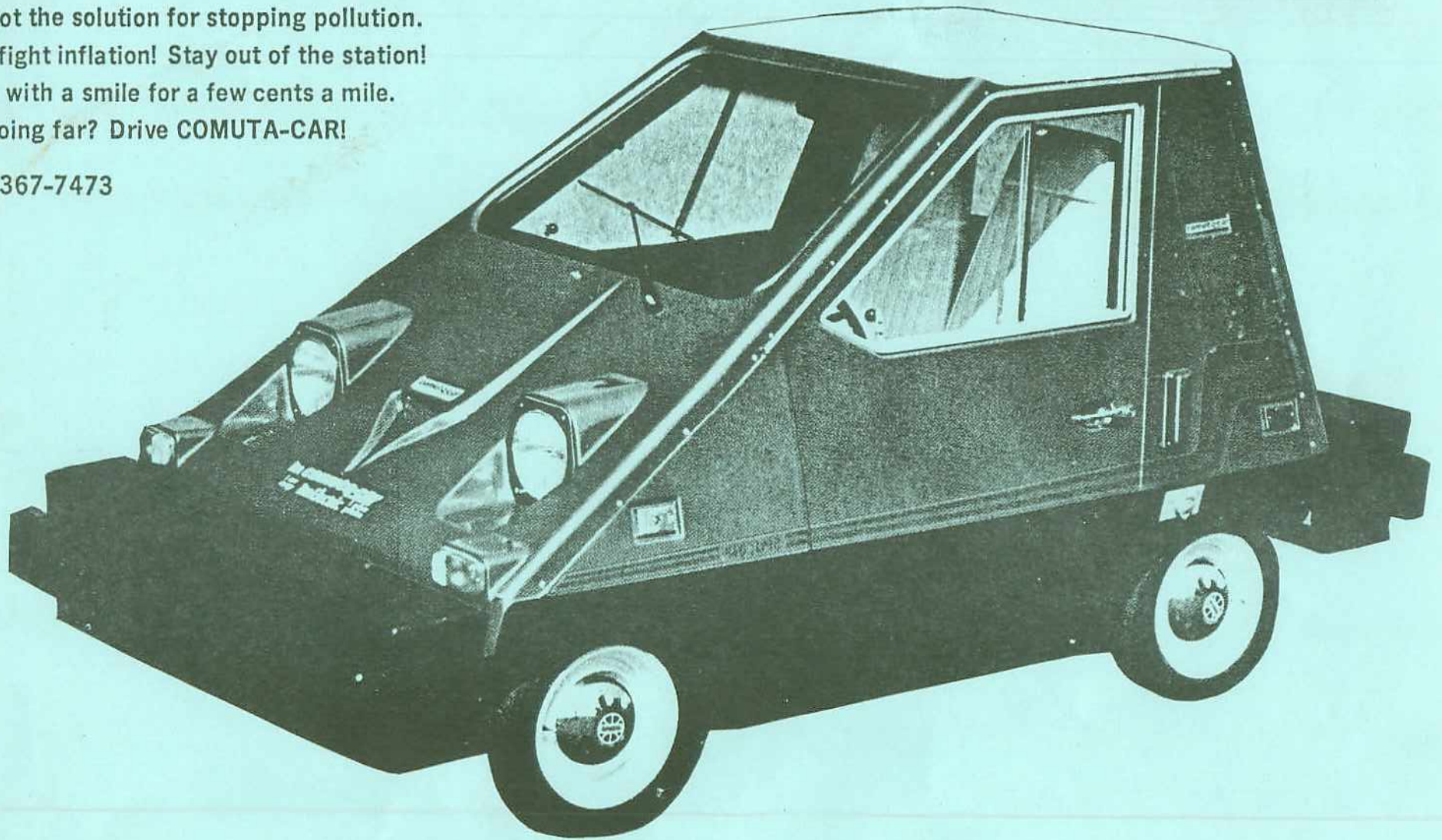

I save
energy

I'm Electric

I reduce
pollution

Acknowledgements & Limitations

This document consists of scans of an original Sebring / Vanguard ComutaCar (CitiCar) dealership maintenance manual, as well as advertisements, specifications, supplements, and Technical Service Bulletins relating to the vehicle.

The information contained herein is believed to be out of print and to have no commercial value. The scanning and compilation of this information is being provided as reference material to Electric Vehicle owners, and those interested in Electric Vehicles.

THIS DOCUMENT MAY BE REPRODUCED WITHOUT RESTRICTIONS, AND IS TO BE REDISTRUBITED FREELY AT NO COST

TABLE OF CONTENTS

	Page
Specifications	2
Service Procedures	3
Troubleshooting	
1. Power Lamp (on/off) (Vehicle Does Not Move)	3
2. High Power Electrical (Vehicle Does Not Move)	4
3. Park Brake Switch	4
4. 12 Volt Low Power Electrical For Controller	6
5. Test Checks for Low Power to Controller	7
6. High and Low Power Electrical Problems (Vehicle Starts in Second)...	9
7. Vehicle has no High Speeds	9
8. Contactor Repairs.....	9
9. Other Controller Problems	10
10. Vehicle Speed	12
Accelerator	12a
Accelerator Spring Modification	12a
Disk Brakes (up to Car 2011)	13
Drum Brakes (after Car 2011)	15
Charger	16
Hot Lamp Warning Circuit	20
Dashboard Electrical	22
Wiper Motor	22
Horn	23
Dash Dimmer	24
Defroster Switch	24
Turn Signals	25
Brake Warning Lamp	26
Forward & Reverse Dash Control Switch	27
Batteries	27
General Maintenance Instructions	30
Transaxle	30
Transaxle Tool Kit	39
3 ½ HP General Electric Motor	41
Routine Examination & Brush Replacement	41
Brush Replacement	41
Cleaning	42
Disassembly	42 (4), 43
Inspection of Armature	43
Commutator Inspection and Care	44
Inspection of Field Windings	45
Bearing Inspection and Care	45
Reassembly	46
Light Bulb Chart	48

Fuse Chart	48
Instructions for Defroster	49
Schematics	
Battery Installation and Battery Box Supplement	
Automatic Charger Circuit Supplement	
Contactor Disassembly and Reassembly Supplement	
DuPont Paint Numbers	
Technical Bulletin 1980 - 102 Brake Lamp Switch Stays in On Position	
Technical Bulletin 1980 - 104 300 Amp Fuse Failure	
ComutaCar Ad Trifold Q&A + Specifications Pre 1979	
ComutaCar Ad Trifold Q&A + Specifications 1980	
ComutaCar Ads (blue and yellow)	

List of Tables & Diagrams

	Page
Specifications	2
Hand Brake	5
Diode Mounting Assembly	11
Accelerator Mount and Spring	12a
Charger Circuit Wiring	19
Diode Circuit Check	19
Hot Lamp Circuit	20
Remove Speedometer Seal	31
Replace Speedometer Seal (cut-away)	31
Remove intermediate gear from pinion Shaft	33
Disassemble Differential	34
Transaxle Parts Diagram	36
Transaxle Parts List	37-38
Toolkit	39
Transaxle Toolkit Components	40
Electric Motor Brushes	42
Light Bulb Chart	48
Fuse Chart	48
Diagram for Installation of Defroster	
Upper Half Contactor Parts Blow-Up	
36V Charger 24SR1001 Wiring Diagram/Schematic (2 pgs)	
High Power Diagram SV48	
Installation Board, Warning Light, PC	
Diode Mounting Assembly	
Contactor Wiring / Connections	
Power Cables & Connectors	
Turn Signal Wiring	
Wiring Diagram After #1751 (2 pgs)	
Schematic Wiring SV-48 (1 of 2)	
Spring Starter Resistor Assembly SV-48	
Battery Installation Layout	
Bumper & Battery Box Diagram	
Automatic Charger Circuit	
Contactor Cross Section	
Brake Lamp Switch Diagram	
Recommended Cut-Out Holes in Contactor Cover	
300 Amp Fuse	
Specifications – Pre 1979	
Specifications – 1980	

INDEX

	<u>Page</u>
PREFACE	1-2
SPECIFICATIONS	2
1. MECHANICAL	
A. Brakes – Hydraulic	13
B. Brakes – Parking	4-5
C. Transaxle	30
D. Vehicle Speed	3-9-12-12a
2. ELECTRICAL	
A. Batteries	27
B. Charger	16-19
C. Contactors	9
D. Dash	22
E. Dash Dimmer Switch	24
F. Defroster Switch	24
G. Diode Diagram	11
H. F&R Switch	27
I. High Power	4
J. Horn	23
K. Low Power	9
L. Motor	41-47
M. Turn Signals	25
N. Wiper Motor	22
3. LIGHT BULB CHART & FUSE CHART	48
4. SCHEMATICS	
5. SUPPLIMENTS	

Howard Anderson
AMCO RESEARCH INDEX

P.O. Box 400
NAPERVILLE ILL 60566

	<u>Page</u>
PREFACE	1-2
SPECIFICATIONS	2
SERVICE PROCEDURES	
1 - MECHANICAL	
A. Brakes - Hydraulic	13
B. Brakes - Parking	4-5
C. Transaxle	30
D. Vehicle Speed	3-9-12-12a
2 - ELECTRICAL	
A. Batteries	27
B. Charger	16-19
C. Contactors	9
D. Dash	22
E. Dash Dimmer Switch	24
F. Defroster Switch	24
G. Diode Diagram	11
H. F&R Switch	27
I. High Power	4
J. Horn	23
K. Low Power	9
L. Motor	41-47
M. Turn Signals	25
N. Wiper Motor	22
3 - LIGHT BULB CHART & FUSE CHART	48
4 - SCHEMATICS	

brakes will be on all four wheels.

The motor is a 3-1/2 HP General Electric traction motor. It will drive the CitiCar through a differential to a speed of 38 to 40 MPH.

A 48V charger is built into the CitiCar with an outlet box on the fender for customer convenience. It has a built-in interlock that cuts the current to the rest of the vehicle when the cord is plugged in, preventing driving away with the cord still attached. A micro-switch interlock is attached to the hand brake to prevent you from driving with the brake partially on.

We have made every effort to construct the CitiCar as a long-lasting people-mover, from the all-aircraft aluminum frame to the ABS Cyclocac plastic body. We have designed it with you, the serviceman, in mind.

SPECIFICATIONS *

LENGTH:	95"	TURNING CIRCLE:	22 ft.
WIDTH:	55"	CONTROLLER: . . .	Vanguard multivoltage speed control.
WHEELBASE:	63"	MOTOR:	Series wound DC 3.5 HP.
HEIGHT:	58"	TRANSAXLE:	Direct gear drive.
FRONT TRACK: . . .	43"	SUSPENSION:	Leaf springs, front & rear. 4 wheel shock absorbers.
REAR TRACK:	44"	BODY:	Impact resistant Cyclocac® (ABS) rust & corrosion proof.
CLEARANCE:	5 1/2"	FRAME:	Rectangular aluminum chassis, tubular aluminum body support.
WEIGHT:	1250 pounds.	BRAKES:	Four wheel - front disc. rear drum - parking.
REAR STORAGE: . .	12 Cu. Ft.	POWER SOURCE: . .	Eight 6 volt batteries (HD).
TIRES:	4.80 x 12, 4 ply rated.		
SPEED:	38 mph cruising.		
RANGE:	Up to 50 miles.		
ACCELERATION: . .	0 to 25 -- 6.2 secs. 0 to 35 -- 19 secs.		

SERVICE PROCEDURES

VEHICLE DOES NOT MOVE

This section will give the technician a quick run down as to what to look for if the vehicle does not operate. Most of the areas to check in this section will be explained in full detail in other sections of the Manual.

Note: When making any check of the running gear, the rear wheels must be off the ground.

Note: In this section of the Manual, we will assume the vehicle already has a fully charged battery pack and also that the battery charger is not connected to a 110-volt source.

1. POWER LAMP

Power Lamp Off With Ignition Key On

If brake lamp is on with park brake off, micro switch must be adjusted so as to operate properly (see section on Parking Brake Switch).

Check other lamps on dash to see if any lamps operate. Also, did controller "click" when turning on ignition switch?

If no other lamps operate and controller did not "click" (click noise when turning on ignition switch is the series/parallel contactor switching from 48 volt series charge cycle to parallel for running), check ground fuse in controller. If ground fuse is intact, check fuses under dash.

There are only four other causes of no power at the ignition switch

- a. Bad charger interlock relay
- b. Wire off interlock
- c. Wire off ignition switch
- d. Defective ignition switch

IGNITION SWITCH ON WITH POWER LAMP ON

Vehicle Does Not Move

Is shift switch in forward or reverse? When the shift switch is not engaged in either the forward or reverse position, the controller will make noise but the vehicle will not move.

Does the controller operate properly? Depress accelerator pedal to see if all the parts of the controller work. There should be three distinct clicks, the F&R contactor, the second speed solenoid and the SP contactor.

If all three clicks are heard, check the high power electric for cause and cure (next section).

If only two clicks are heard, check orange and/or green wire on the F&R contactor and/or the shift switch.

2. HIGH POWER ELECTRICAL

Vehicle Will Not Move

Check main fuse or circuit breaker, depending on whether vehicle is 36 or 48 volt.

Main fuse O.K.?

Check F&R contactor for burned points.

Points O.K.?

Check for burned high power cable and a blown 30 or 40 amp ground fuse.

Check to see if the motor studs on the G.E. 3-1/2 HP motor have been cut off. If the armature studs on the aluminum end plate have not been cut off even with the hold down nut, the far rear stud could come in contact with the right rear shock and blow the fuse.

The upper armature bolt in some cases interferes with the movement of the main power cable to the motor and this could cause the insulation to be worn away and could burn the cable in half.

The 40 amp fuse could also blow due to a loose connection in the fuse block itself. The wires and connections at the fuse block should be tightened periodically to assure a tight fit.

X If 40 amp fuse blows more than a few times, the diode above the fuse block should be checked.

3. PARK BRAKE SWITCH

The park brake switch is used to disable the vehicle when parked with the brake on.

The micro switch is activated by pulling the park brake handle up. (See Diagram).

Hand Brake

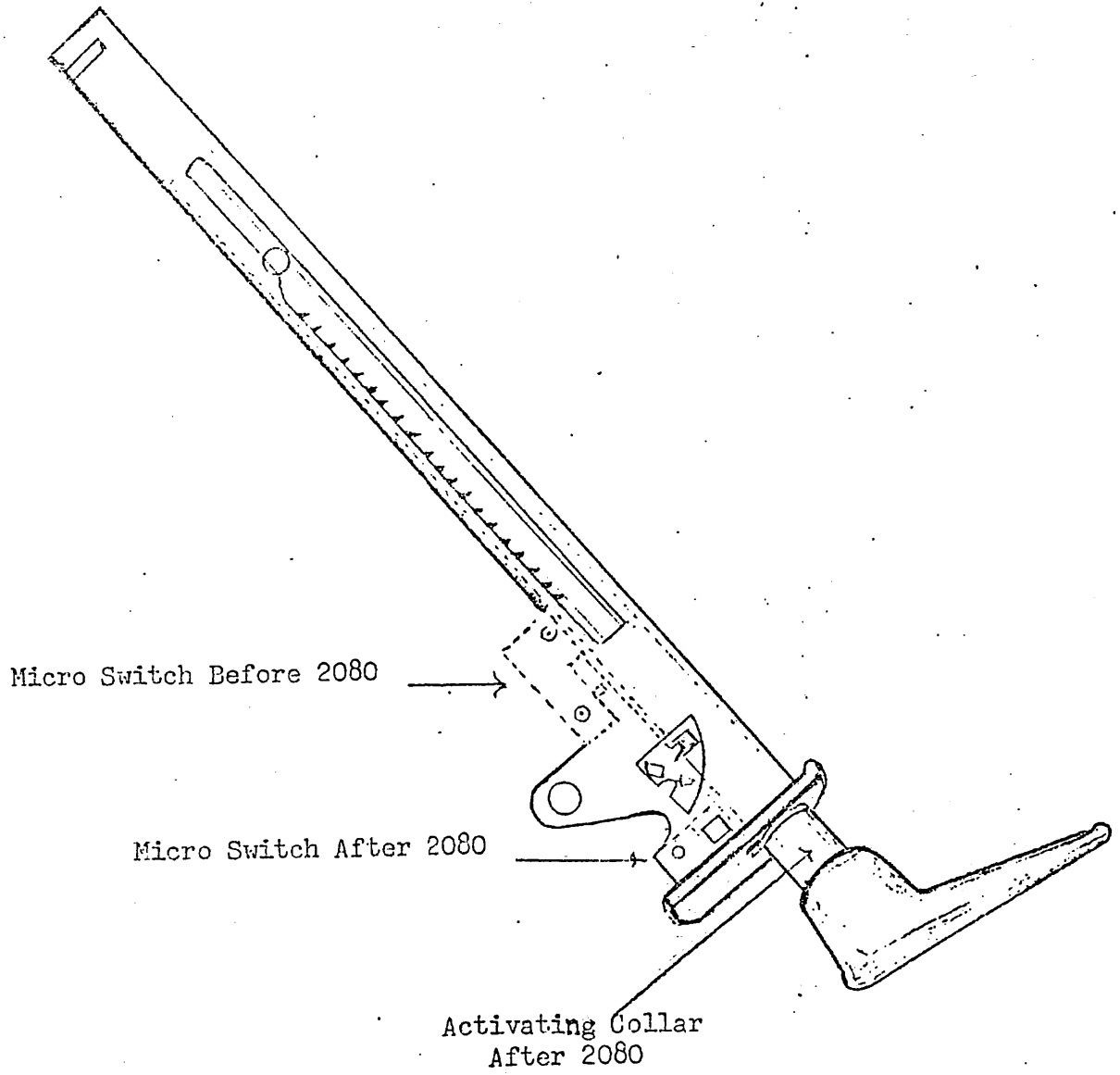

The micro switch activating arm rests in a notch cut into the park brake ratchet arm when the park brake is off, up to CitiCar No. 2080. After Car No. 2080, the switch is relocated and works off a collar on the hand brake.

It is possible for the switch to come out of adjustment from normal use.

If the vehicle does not move when the brake is off, the switch on the park brake could be at fault.

The switch can be adjusted by bending the activating arm with a small screw driver when the brake is off (before Car No. 2080). If this fails to work, then the switch should be removed from the mounting bracket and the mounting holes for the switch enlarged so that the switch can be moved for a better adjustment.

4. 12 VOLT LOW POWER ELECTRICAL FOR CONTROLLER

The controller is operated by the 12 volt electrical power system. This is controlled by the forward/reverse shift switch and the accelerator cam switches. The cam switches at the accelerator activate the three speeds of the controller.

If any part of the controller fails to operate, first check the low power electrical to see if cause is here. If upon raising the rear wheels and checking the workings of the controller and all parts operate, then check the high power.

Low Power Electrical Problems

Vehicle does not move but clicking is heard in control box.

Check F/R shift switch to make sure it is in forward or reverse.

Check to see if wire is off of cam switch. This would most likely be the red wire or the red wire with a black stripe.

Check the F&R contactor to make sure the orange wire is connected to the contactor magnetic coil (green wire if vehicle will not go into reverse).

Check shift switch for loose wire.

5. TEST CHECKS FOR LOW POWER TO CONTROLLER

Is there power to the controller? SV-48 controllers are mounted directly to the plastic floor pan of the vehicle, therefore, they must be externally grounded to the chassis. Some vehicles before Car No. 1751 were equipped with a 16-gauge ground wire that was attached to the forward controller plate mounting bolt and ran through the wiring harness to the battery box where it was attached to the chassis. In some cases a circuit overload during charging could overheat the ground wire and melt the harness wiring to the controller together causing the controller to malfunction. If this happens, the controller harness must be replaced. It is advisable to run the ground wire (using a larger gauge wire) from the forward mounting bolt to the frame. This will eliminate any further harness problems.

On Cars No. 1751 and above, the controller was grounded by mounting the ground fuse block wires directly to the chassis at the rear body panel support frame behind the right rear wheel well.

Once the controller has a proper ground, then the following test checks should be made to find if 12-volt power is going to the controller:

- a. Raise rear of vehicle.
- b. Turn on ignition key.
- c. Using a suitable test lamp, check the purple wires at the accelerator cam switches for juice?
- d. Always check the power flow at the park brake switch first because the juice comes from the ignition switch through the fuse box to the park brake switch, then to the cam switch, on to the F&R dash switch and the controller. If the park brake switch is out of adjustment, broken, or wired incorrectly, the controller will not operate. If the switch does not show visual damage and seems to be operating properly, connect the green and the purple wires together. If this enables the vehicle to operate, the park brake switch must be replaced.
- e. With the accelerator depressed, check the first and second speed switches for power leaving the switch (brown and red wires).
- f. With the accelerator in the off position, check the third speed switch for power. The (3) third speed switch is a normally closed switch (meaning power flows through it when it is in the off position).

- g. If there is power through the switches, then proceed to the controller low power wiring.
- h. To check the F&R contactor wiring, the F&R dash switch must be in either forward to power the forward coil or vice versa for reverse. The first speed cam switch sends juice to the F&R dash switch which controls the F&R contactor coils.
- i. If there is power at the cam but no power at the controller, check the wire harness carefully for broken wires.

On some SV-48 vehicles and all 36-volt vehicles, the F&R contactor operates forward low speed when the points move to the top position. Reverse is achieved when the points contact in the lower position. All other SV-48 vehicles activate in the reverse order. Sebring-Vanguard suggests that vehicles be modified to the latter operating condition for most reliability.

To find out which way the F&R operates, first remove the controller box cover and look to see where the cables attach to the F&R contactor on the side facing the 1/4 panel. If the cables are on the top of the contactor, forward activates at the top; cables at the bottom - forward at the bottom.

Usually the points that burn out are the forward ones and replacing all the contactor points may not be necessary. Some points may not be burned out but may be lightly pitted and may only need to be cleaned or filed lightly to be serviceable.

In some cases a large carbon burn deposit may form on a point or points causing a bad connection and no power will flow through the connection. By cleaning or filing the carbon deposit, the point or points are again serviceable.

Loose connections at the contactor cable connections can cause contactor and/or cable burnout. Always keep all connections tight. A loose or bad connection can cause a no-power flow condition which would result in a burned contactor point and vehicle malfunction.

Always look into the contactor arm point area to make sure that the points are actually making contact. They must make a good contact with each other to let the power flow to the motor.

When replacing points, make sure the movable bridge points are not bent as this will cause a bad contact and early failure of the repaired unit. A bent movable bridge can be straightened with a pair of pliers. If the points are not making a good contact, and the points do not look bent, the cause may be an overheated bridge spring in which case the spring must be replaced or the contactor points will definitely burn out.

6. HIGH POWER AND LOW POWER ELECTRICAL PROBLEMS

Vehicle starts out in second speed.

Check the resistor coil under the chassis to make sure that the coil and/or the cables are burned off. Also, if the car starts out in second speed after the coil has just been replaced, then the cables were reinstalled improperly.

If everything looks O.K. under the chassis, check the F&R contactor to see if one of the points is burned off.

If the vehicle starts off in second speed by the F&R contactor and the solenoid engaging at the same time, check the accelerator switch for loose connection. If the wire from the first speed micro switch comes in contact with the second speed switch, both speeds will work at the same time.

7. VEHICLE HAS NO HIGH SPEEDS

Check the accelerator pedal assembly for proper throw. Does the vehicle go into high speed before the pedal reaches the floor? If not, pull the accelerator rod off of the pedal arm and activate the cam switch. If the vehicle goes into high speed, then the rod adjustment must be corrected or the pedal may have to be bent.

If this is not the case, check for a burned set of points on the SP contactor.

8. CONTACTOR REPAIRS

Repairs are very simple if you keep in mind that you are only replacing parts. There is no real adjustment that can be made. The adjustments are made at the factory and should not need to be changed.

It is recommended that the contactor be repaired and not replaced if only the points are burned out. If the points and the coils are burned out at the same time, the complete assembly should be replaced.

When any repairs are attempted in the controller, the batteries should be disconnected to prevent any electrical short.

Both the F&R and the SP contactors are taken apart in the same manner.

- a. Disconnect the batteries.
- b. Remove the controller box cover.

- c. Remove the cable connections and the buss jumpers from the top insulator plate.
- d. Remove the 4 small nuts and washers from the insulator plate. This will enable you to remove it.
- e. If the bottom point set is burned, the center movable bridge must be removed. This is done by removing the nuts on the top of the movable bridge towers and removing the parts. It is best to lay the parts out in the position that they were removed so they can be reinstalled in the same manner.
Remember: When making any repairs to the contactors where disassembly is necessary, the springs under the movable bridge assembly MUST be replaced. This is a common cause of contactor failure.
- f. Reassemble in reverse order.

9. OTHER CONTROLLER PROBLEMS

If high speed contactor fluctuates or vibrates when engaged, the CitiCar may have a very low battery charge.

Check for bad battery and/or loose connection on a battery.

When making any repairs to the F&R contactor, check the diode assembly (mounted on the solenoid mounting plate) to make sure it is functioning properly. If voltage passes only one way through the assembly, it is good. If voltage passes both ways, the unit must be replaced.* Use a battery powered continuity tester or voltmeter. The diode is used to prevent an amp throwback on the contactor from the motor when changing speeds.

There are no repairs to be made on the second speed solenoid. If found defective, it must be replaced.

*NOTE: When replacing the diode, always replace the mounting kit (consisting of the mica washers and the insulating insert). Be very careful to install all the parts per the illustration. If the mica washer gets cracked or broken, or if the plastic insert is left out, the diode will ground itself and be useless.

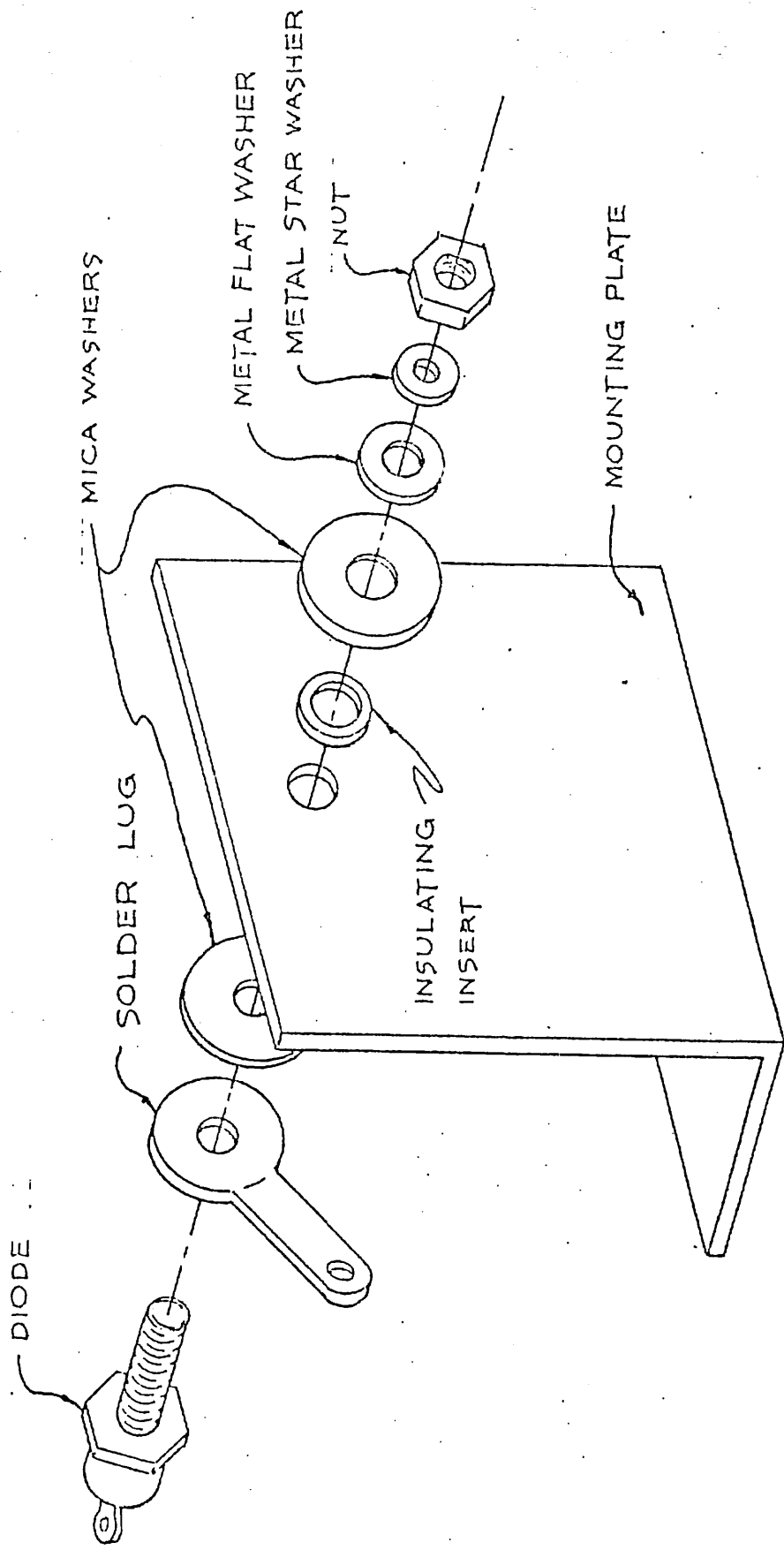

DIODE MOUNTING ASS'Y (KIT)

10. VEHICLE SPEED

There are many factors in maintaining the vehicle speed.

Does the owner drive with his or her foot on the brake? This will not only keep the vehicle speed down, but will cause early failure of other parts of the vehicle.

Riding the brake will wear out the brake pads prematurely and will also overheat the batteries, controller and motor which will severely reduce the vehicle range.

Inherent brake drag will also reduce the vehicle speed.

Constantly running vehicle with poorly charged batteries will keep speed down.

A motor that consistently draws too many amps will make the vehicle run slow, will heat up and result in a loss of range as well as speed.

These problems and cures will be covered in other sections of this Manual.

Outside temperature, road grade and wind speed also contribute to vehicle speed being slow.

ACCELERATOR

The accelerator is a cam which activates 3 micro switches in succession to supply the motor with 3 different voltages.

The first position transmits 24V through a resistor suspended above the right rear spring. The resistor burns off 6V and allows 18V to go to the motor for starting. In this speed the CitiCar will go about 11 MPH.

In the second position the resistor is bypassed and 24V will go to the motor and drive the CitiCar 23 MPH.

In the third position the SP contactor changes the current from parallel to series and provides 48V.

The first 2 micro switches allow current to flow. The third works opposite. It cuts current flow to the SP and allows the spring loading to return the SP to its normal position which puts the current in series. The SP is in this position during the charging period.

ACCELERATOR SPRING MODIFICATION

Below is a diagram showing the installation of the new spring along with the auxiliary spring. The new spring is attached to the same hole at the top of the accelerator pedal and extends to the bottom of the bracket which holds the cam. The auxiliary is attached to the same hole at the top of the pedal but requires a 1/8" hole be drilled in the cam bracket.

This section applies to cars before serial numbers ending with #2426.

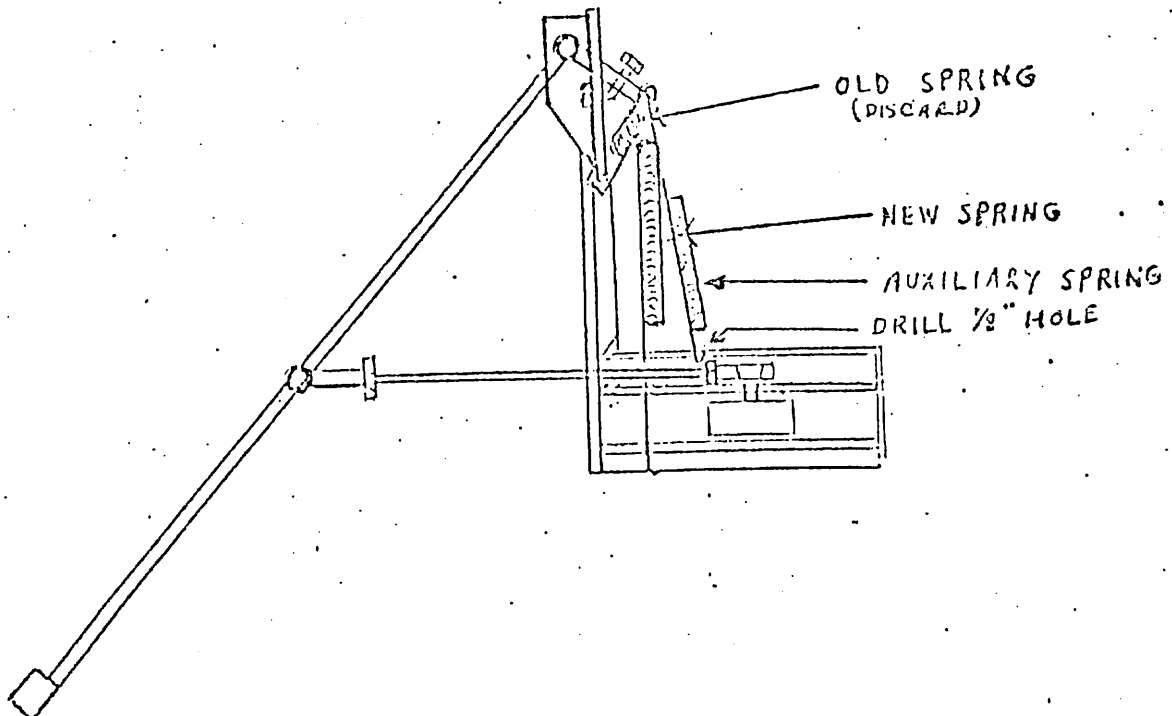

DISC BRAKES
(UP TO CAR NO. 2011)

1. SYMPTOMS

- a. Hard Pedal
- b. Loss of Pedal
- c. Pulls to right or left

a. HARD PEDAL

Most likely due to unequal pressure between front and rear system.

Check vehicle to see if self-adjusting system on rear brakes has been reset in the following manner.

Raise vehicle. Remove rear wheels and brake drums. Loosen self-adjusting rod locking bolt and nut until it can be rotated freely by the fingers. Retighten bolt until friction just overcomes pull of spring mounted between shoes. Reinstall the drums and wheels. Adjust the brake system by pushing brake pedal hard three times, then take up on the park brake adjuster until the rear wheels cannot be turned. Loosen the adjuster until the wheels move freely. Lock the park brake adjuster cable with its lock nut. Handle should pull up no more than 2" in normal use.

Pump the brake pedal a few times to even the fluid pressure in the system. This should make the pedal softer and improve the functioning of the complete system.

b. LOSS OF PEDAL

- (1) This can be caused by either air in the system, by a defective part in the master cylinder, or a loose connection in the system.

First, check the complete system for fluid leaks and tighten any connections that are leaking.

- (2) If no leaks are found, it is advisable to bleed the complete system to remove any possible air that may be trapped in it.

Always start with the right rear wheel, then the left rear, the right front and, lastly, the left front. Always bleed each wheel cylinder until the fluid is the same color as the new fluid that is being installed in the master cylinder. This assures that new fluid is passed completely through the

system and should indicate that all the air is bled out of the system.

- (3) If after trying (1) and (2) and loss of pedal still occurs, check the master cylinder for defective parts.

Most likely, the check valve will be at fault, but check all the parts for possible defects. Look for torn seals or dirt in the fluid. Overhaul the complete master cylinder if necessary. Bleed complete system.

Teflon tape should be on all joints where dissimilar metals are joined in the brake line system. If it is not, you should install it.

c. VEHICLE PULLS TO RIGHT OR LEFT DURING STOPS

This is usually caused by the front disc calipers sticking due to dirt or corrosion building up.

Remove outer disc pad and remove caliper from spindle; clean caliper pin bushings and check to see if the bushings are seated against the spindle plate. Check the end play of the caliper and make sure the caliper pins and bushings don't bind. Clean any debris or dirt out from behind the inner disc pad. Check the caliper piston movement to make sure the return springs on the disc pad are pulling the piston back against the caliper. If not, then the caliper should be disassembled, cleaned of any foreign particles, and a new "O" ring installed.

When reassembling the parts, use some anti-sieze compound on the parts. Coat the face of the caliper piston groove; also, the guide pins and bushings. The anti-sieze compound is better than regular chassis lube, due to the fact that it wouldn't wash out as easily as chassis grease.

2. PROBLEMS IN THE BRAKE SYSTEM CAN BE THE REASON FOR OTHER MALFUNCTIONS

A vehicle that will not attain at least 35 MPH may have improperly adjusted brakes or front calipers that are bound up in the guide pin bushings, or caliper pistons that do not return properly.

All of the above lead to severe brake drag and not only can cause a slow vehicle, but also will reduce its full range and premature battery aging.

One of the best checks for brake drag is to have the vehicle on a flat, level surface. Then, with the park brake off, push the vehicle with one hand. If it rolls easily, it could be safe to say that there is very little or no brake drag.

A vehicle that has brake drag which is left uncorrected for a long period of time will most likely have battery trouble because the vehicle will work harder to overcome the drag problem and heat up the batteries, not only causing short range but needlessly shortening the battery's life.

The front disc pads and rear shoes should be periodically checked for wear and must be replaced before the attaching rivets come in contact with the rotors or drums.

When the disc rotors and/or rear drums get scarred or gouged by the metal-to-metal contact of the rivets or the backing plates, it is recommended that the rotor and/or drums be replaced.

DRUM BRAKES
(AFTER CAR NO. 2011)

The symptoms remain the same as with the disc brake installation and remedies are similar down to Paragraph C, "Vehicle Pulls to Right or Left During Stops". Disregard this section and proceed as follows:

1. Remove wheel and drum.
2. Inspect lining for grease or other foreign matter.
3. If any foreign matter is found, remove with Brake Kleen. This product is available at all auto stores.
4. Inspect cylinder for leakage. If none, inspect grease seal and replace if evidence of leakage.
5. Reassemble.
6. Drive vehicle at top speed down road with light foot pressure on brake pedal for about 100 yards. Release for 1/4 mile and repeat. This should remove glaze from brake shoes and insure even stop.

NOTE: There is a dual master cylinder employed in the drum brake installation.

CHARGER

NORMAL OPERATION - ONBOARD LESTER CHARGER

The state of discharge of the batteries will be slightly different every time they are put on charge, but the charger varies automatically the initial charge rates, and taper off of charge rates over the charge period. Thus, the initial charge rate will drop quickly to a lower value, then taper gradually over the charge period to a finish rate of 1-4 amps for the last 1-3 hours.

When batteries are slightly discharged, the ammeter needle will be in the 1-4 amps area for 7-8 hours, but the specific gravity will not rise to full charge until the cells have been equalized. The normal charging with the ammeter needle in the 1-4 amps area is important to achieve equalization of all battery cells every time the batteries are charged. Since the taper of the charging rate (in amps, as indicated by the ammeter needle) is controlled by the rising voltage of the batteries being charged, proper performance of the charger and resulting good battery life is dependent on upon the following factors:

1. An adequate AC line to handle the power required. An electrician or the power company should survey any questionable installation.
2. All cells of the batteries must be good, raising to approximately 2.5 DC volts per cell while still on charge or near the end of a 12-hour charging period. When in doubt, check each cell with a single cell voltmeter while still on charge. If a low reading is obtained, check the low cells with a temperature corrected hydrometer.

NOTE: Hydrometer float must be thoroughly clean to obtain accurate specific gravity readings.

3. Battery and controller connections of the vehicle must be clean and tight.
4. The timer knob is set to "ON" (12 hours) as long as ammeter needle tapers down into green area toward the end of the 12 hour period.

TROUBLE SIGNS

The necessity of adding water more frequently than two or three weeks, and/or hot battery cases at the end of the charging cycle, indicates the finish rate is too high, due to one or both of the following:

1. One or more bad cells in the batteries.

2. Batteries are starting to age. In this case, batteries should be charged at a lower rate. A good way to do this is to charge the batteries in two stages of 6 hours each with a rest period of at least 2 hours. This gives batteries a chance to cool and will result in a better charge.

CAUTION:

Due to the electrical characteristics of this charger, it is possible to improperly hook up the batteries and not blow the fuses when charging. When installing batteries, be sure polarity is correct. With a DC voltmeter, check terminal voltage and polarity at the vehicle wiring terminals. When working near capacitor terminals, be sure charger is turned off. With charger "on", transformer capacitor terminals provide a very high voltage. Care is to be shown.

Ammeter Does Not Register and No Transformer Hum

In the event no hum is detected from the transformer, check the circuit from AC plug to transformer primary with a suitable continuity tester. This would include AC cord, timer and connections.

Transformer Hums But No Ammeter Indication

Remove the DC fuse on the front of the charger and check for continuity. Replace any blown fuses. Also, check the ground fuse circuit in the control box. Check to see if the positive charger lead is connected to the 48 volt positive battery terminal.

1. Remove positive charger lead from battery, using a low voltage continuity tester. Connect clip lead (-) to chassis and test probe (+) to charger wire. Circuit should be complete. If not complete, it can be assumed an "opening" in the complete DC circuit exists; check fuses, fuse holder connections, DC cord and diode connections.
2. If circuit is complete, then reverse test light leads. Circuit should not be complete. If circuit is complete, then probably one or both diodes in the charger have shorted.
3. If 1 and 2 check O.K., check for shorted capacitor. Remove one wire from a capacitor terminal and place test clip from lamp on terminal. Probe to other terminal. If circuit is complete, capacitor is shorted and must be replaced.

Charger Fuse, One or All, Blow as Soon as Charger is Fully Installed Into Vehicle

This condition may be caused by:

1. Reverse polarity between charger and batteries, such as incorrect installation of batteries or positive charger lead.
2. A short circuit failure of one or both diodes. First, disconnect one diode. With a low voltage continuity tester, current should pass in one direction only through the diodes. Connect one lead of the tester to the diode mounting plate. Connect the other lead to diode lead. Then reverse test leads. If diodes allow current to flow in both directions, replace entire heat sink assembly.

Charger Fuse Blows During Charge

This may be caused by a loose fuse. Charger fuses should be screwed in at maximum hand tightness. A weak fuse or poor fusehold or connection can also cause this condition. Always check the ground fuse holder and connections in controller box and battery compartment for looseness.

AC Line Circuit Breaker Opens or Fuse Blows

If this happens when charger is turned on, disconnect positive charger lead from batteries. If this still happens, the diodes, timer motor coil, or transformer may be shorted. To check timer motor coil, disconnect one primary wire leading to timer and connect test lamp to coil terminals. If lamp glows, coil is shorted. To check transformer, disconnect transformer secondary leads #1 and #4. If the AC fuse still blows or breaker still opens after such disconnection, the transformer is shorted and must be replaced.

Charger Does Not Turn Off And/Or Timer Knob Does Not Move

Replace timer.

Charger Output Is Low

Probable cause is one diode failing (shorted), blowing one fuse. Replace fuse. If fuse continues to blow, check for diode failure.

Transformer Shorts or Burns Out

Failure of transformer may be caused by natural aging or premature shorting of adjacent coil turns. Symptom is low or complete lack of output and can be observed on ammeter. However, charger may still hum when timer is "ON". Replace transformer or complete charger.

CHARGER CIRCUIT WIRING

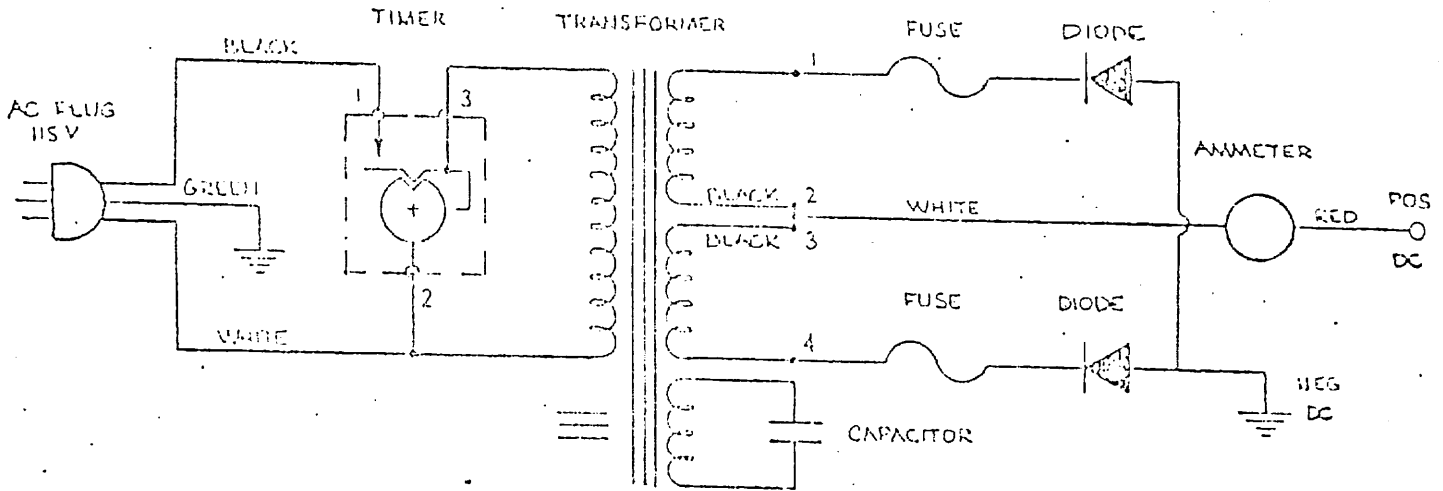

DIODE CIRCUIT CHECK

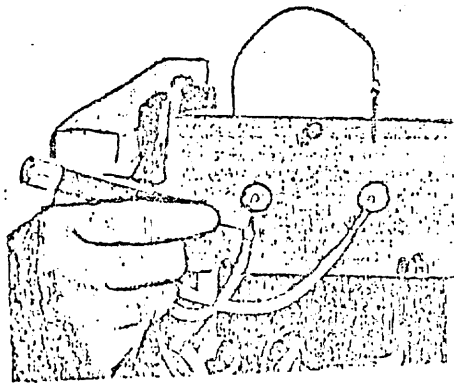

HOT LAMP CIRCUIT

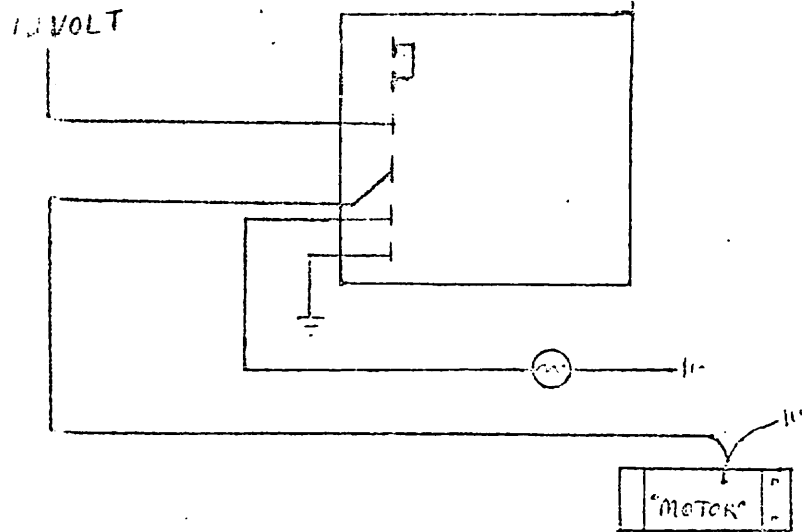

The hot warning lamp is used to indicate an overheating condition in the motor. The motor is designed to operate between 185° and 195°. The hot light comes on at 225°.

Connected to the motor field windings by the use of fiberglass tape, one will find the thermal switch sensor; this is used to measure the motor heat. The sensor is connected through the wiring harness to the printed regulator circuit board, mounted on the back of the speedometer head. When the motor gets hot, the thermal switch opens and the regulator board turns on the lamp indicating a hot condition at the motor.

TROUBLE SHOOTING

If it is thought that the hot lamp is not operating properly, the following checks should be made.

1. Hot Lamp Stays On After Key Is Turned On

- a. Check for loose connections in the circuit. If the circuit is not complete, the register board will not operate and the lamp will not go out.

Check all the connections on the circuit board to make sure they are tight.

- b. Connect a jumper between the thermal switch lead connector and the harness connection and a suitable ground. This should be done where the motor leads connect via butt connectors to the harness. If the lamp goes out, the switch (inside the motor) is not working and it should be replaced.

2. Lamp Lights After Driving the Vehicle a Short Distance

- a. First, ground the system as in Part 1b. If the lamp goes out, the thermal switch may be working properly.
- b. Tape a metal meat thermometer, or any thermometer that will register to 250°, to the motor and run the vehicle until the lamp comes on. Check the thermometer. If it reads a temperature less than 225°, the circuit board is not operating properly and should be replaced.
- c. If the lamp comes on at 225° or over, then the motor is hot and it may need to be replaced.

HOT LAMP CIRCUIT NOTES

In vehicles with serial numbers below 1751, the thermal switch was connected to a light green wire that ran to the PC board. The other switch wire was either connected to the motor field bolt, the end plate bolt or direct to the chassis frame rail.

The color code for the wiring did not always match what was on the circuit print.

In vehicles 1751 and above, the switch lead to the PC board is yellow and the other lead is connected to the chassis ground wire at the harness.

Also, the top two leads on the PC board which are wired on the late production vehicles (after 1750) are used for the brake warning lamp circuit to be used when the vehicle has the dual master cylinder installed.

DASHBOARD ELECTRICAL

Upon checking any switch or lamp on the dash, check to see if the switch or lamp is getting power to it. (A test lamp should be used for this). In most cases, a problem can be traced to the fuse box, either a blown fuse or a loose connection at the fuse box.

In the case of a bad lamp, it must be noted that in vehicles before serial number 1751 the bulb can be replaced by pulling the socket out from behind the dash and replacing the bulb. In vehicles 1751 and above, a burned out bulb also means either replacing the bulb socket or the switch that the bulb is in.

If the ground wiring at the dash panel has come loose or has fallen off, the dash lamps will intermittently flash on and off and the turn signal actuation will cause all the lamps in the vehicle to flash.

Head Lamps, Tail Lamps and Marker Lamps

If the bulb is not burned out, it is then usually the power connection or the ground connection to that lamp that has come loose.

On earlier model vehicles (up to car 1750) with floor mounted high beam switch, check the connection at the switch. If the head lamps do not work, also check to see if the switch works.

WIPER MOTOR

There are two types of wiper motors used. Some vehicles have the Delco Remy and others have American Bosch.

The type can be distinguished by the wiper arm. The Bosch unit has the wiper arm fixed to the motor shaft by the use of a large crown nut. The Delco arm is pushed on.

If the wiper does not work, check for blown fuse. Then check for power to the switch. Check for power away from the switch. If there is power to the motor but it still does not work, check the motor transmission and wiper arm to see if something is holding it from working. If not, replace the motor.

WIPER MOTOR WORKS BUT DOES NOT PARK WHEN TURNED OFF

Some Delco motors had a transistor canceling device mounted on the wiper motor chassis mount. If the motor does not cancel, replace this device. If the motor still does not cancel, then replace the motor after checking all the connections.

Other Delco equipped vehicles had a self-canceling dash switch. Check the switch first to see if the brass cross bar (on the back of the switch) is intact. If so, check all wiring connections. If they are O.K., then the motor is bad.

On the Bosch motors, first check wiring at the wiper switch, then check the diode plugged into the switch. If they are intact, then the motor is probably the cause of the malfunction.

WIPER MOTOR NOTES

It should be noted that all Delco wiper motors were connected on the 18 volt circuit serving the voltmeter, horn and wiper and the voltage was stepped down to 12 volts by a resistor that was mounted on one of the anchor bolts of the motor. This should always be checked when trouble shooting motor problems and replaced if it is not sending a full twelve (12) volts to the motor. If the resistor is sending more than 13.8 volts, it should also be replaced as more voltage than 13.8 will damage the motor.

HORN

VEHICLES BEFORE SERIAL NUMBER 1751

In vehicles before serial number 1751, the horn was on the 18-volt circuit and is mounted on the front chassis cross member. The horn mounting bracket is insulated from the vehicle chassis by nylon washers. This is because the horn has power to it at all times. The horn button grounds the circuit thereby blowing the horn.

If the horn does not work, check it by grounding the horn to the chassis. If it works, then check all the connections. Make sure that where the power wire bolts to the horn that all the paint is cleaned off the connection. Check the plug-in connection for the horn button wire and clean it. Check the horn button plate and clean it. Check the horn button in the steering column to make sure that it makes contact with the horn button plate.

The horn also has an adjustment screw which can be turned if the horn will not work after all the other parts have been checked.

If the horn still does not work, replace it.

VEHICLES AFTER SERIAL NUMBER 1751

The horn is activated by pushing in the turn signal lever. These vehicles operate at 12 volts.

The power for the horn goes first to the horn button and the horn itself completes the ground.

If the horn fails to operate, first check the fuse. Then check the horn with a jumper wire connected to 12 volts; if the horn works, the horn button at the turn signal may be at fault. However, the circuit should be checked for continuity before replacing the signal assembly. Also check the horn button connection in the signal assembly for dirt or corrosion which also keep the horn from working.

DASH DIMMER

The dimmer receives its power from the head lamp switch.

If the dash lamps will not dim, the resistor pot in the switch may be bad. The complete dimmer switch should be replaced.

On vehicles after serial number 1751, (and until further notice), the dash lamps will not dim to the point where they go completely out. This is due to the use of the same dimmer as in early production vehicles and also the usage of less lamps, so there is not enough resistance created to completely turn them out.

DEFROSTER SWITCH

The defroster switch is not connected. Because of Federal regulations, it must be installed in every vehicle built, even though not connected.

Owners of earlier vehicles may now purchase the new optional defroster and have it installed.

Note: In some early production vehicles with factory-installed heaters, the electric start heater switch may have been connected to the defroster switch. If this is the case, you may reconnect the heater to the red and black wires that are located under the dash above the charger. This was only done on some vehicles below serial number 1751.

TURN SIGNALS

VEHICLES BEFORE SERIAL NUMBER 1751

Signal Stat Model 900 is not self-canceling.

Most problems with this turn signal system can be traced down to a bad fuse, blown bulb, a bad connection at the lamp, or a bad flasher.

If the complete system is out, check the fuse.

In some vehicles, there is a fuse in the circuit line between the fuse box and the flasher.

If one side or the other is out, check to see if the complete side is out. If not, it may be a bad bulb or loose connection.

Most times the rear lamps go out due to the connection coming loose.

If the complete side system is out, it most likely is the flasher.

If the indicator lamp is out: first check the bulb by removing the housing cover at the signal indicator. If the lamp is not bad, the flasher is most likely out.

Before the flasher is replaced, check the connection on the blue wire for continuity and check the flasher housing for proper ground.

NOTE: On some early production SV-48 vehicles, the rear turn signals were reversed because of the wiring harness being relocated to the right side of the chassis. The wiring harness connection plug under the dash has been changed to correct this situation. On these vehicles the yellow and green wires are inter-connected at the connector block.

VEHICLES AFTER SERIAL NUMBER 1751

Self-canceling type.

These units are English Lucas units and incorporate not only the turn signals but also the high beam, high beam flashing device and horn.

They work basically the same as the earlier type, but use two (2) relays mounted on a plate behind the dash just above the steering column.

The relays are spring loaded to hold them in the off position until the relay coil is activated for each side.

If malfunction occurs, always check for a burned out light bulb. If the dash indicator lamp fails to operate, it is most likely the relay spring tension for that side.

Check the fuse and if fuse is intact, check relays. If relays operate properly, replace flasher.

Remove the relay board from the dash and engage the turn signal lever for the side not working.

Depress the relay for that side with a finger. If the lamps operate, then bend the spring mount slightly so that the relay activates.

Turn the signal to the off position to make sure the signal relay shuts off. If it does not, then the spring mount has too little tension and must be rebent.

NOTE: If a complaint should arise about the signals not always canceling, check the canceling pin in the steering wheel to make sure it is properly seated into the canceling locator slot. It may be necessary to install a small piece of rubber hose (1/2" to 5/8" long) over the pin to take up some of the slack in the slot in the plastic sleeve to make the canceling locator cancel the turn signal.

BRAKE WARNING LAMP

On all vehicles before serial number 2211, the brake lamp on the dash is used only to indicate that the park brake is engaged; also to indicate that the vehicle will not move until the park brake is released.

The lamp would also indicate that the switch needs adjustment if the park brake is off and the lamp is on.

On vehicles after serial number 2211, the lamp will also indicate that there may be a problem with the brake system. The light is designed to go on if pressure drops in the system.

If, after working on the brake system (such as bleeding the system), the lamp stays on, then it will be necessary to remove the switch from the regulator block (located on the left front side of the chassis) and re-install it (the switch) in the block to reset the system.

F&R DASH CONTROL SWITCH

Because of its neutral interlock, the F&R dash control switch must be replaced with an exact item.

If for some reason the internal workings of the switch become jammed, do NOT attempt to repair the switch. (The internal parts are spring loaded). The complete switch must be replaced.

BATTERIES

The batteries used to power the vehicle are electric vehicle type, 106 minute, 6-volt batteries and only exact replacements should be used.

Batteries should be kept charged. A battery left in a discharged state will go bad in a very short period of time. Keep all terminal connections clean and tight.

Keep all batteries not only clean but also dry. When moisture builds up on batteries, it can draw the charge out of them.

Only add distilled water and only add that water at the end of the charge cycle. This way, the electrolyte will have expanded to its fullest extent and there will be no chance of the electrolyte spilling over the battery top during charging.

Adding water before the charge will only lead to spilling over of electrolyte and this will kill the battery.

Remember, only add water up to the filler ring in the battery top and never allow the water level to drop below the plates.

BATTERY CHECKS

Inspect the battery visually for case condition (corrosion, cracks) and water level.

If the case is cracked, replace the battery. DO NOT attempt to repair the case.

Remove any corrosion from battery terminals and hold-down plates with a solution of baking soda and water.

CAUTION: Do not get any of the solution into the battery.

State of Charge Test

Always test the state of charge with a temperature corrected hydrometer.

<u>Specific Gravity Reading</u>	<u>Charged Condition</u>
1.260 - 1.280	Fully Charged
1.230 - 1.250	3/4 Charged
1.200 - 1.220	1/2 Charged
1.170 - 1.190	1/4 Charged
1.140 - 1.160	Just about flat ✓
1.110 - 1.130	All the way down

The hydrometer will only give the specific gravity in relation to the state of charge. Even though the specific gravity may read 1.280, the hydrometer will not tell how long that charge will hold up.

The most effective way to test the condition of the charge is to use a battery load tester or test the vehicle under a load.

The load test method will show just how long the battery or batteries will last.

By using a voltmeter on each battery, or a bank of voltmeters on all the batteries, the voltage drop can be recorded to find out what battery, if any, might be causing trouble in the system.

Connect the voltmeter or meters to the battery pack so that the voltage of each battery can be recorded. Drive the vehicle and record the voltage drop.

If, before moving the vehicle, any battery shows less than six volts, that battery should be charged so that the complete pack will be the same. When making this test, all the batteries should have about the same voltage drop. This indicates a good pack of batteries. Any battery that drops back more than 3 volts over the rest of the pack, (if all but one of the batteries dropped back to 5 volts from 6 volts, and one battery dropped to 2 volts) that battery, or batteries, should be considered bad and should be replaced.

If a defective battery is left too long without being replaced, it will pull down other batteries, and they may have to be replaced also.

Batteries are the life of any electric vehicle and should be properly maintained at all times.

When checking the battery pack, always check the battery cables and cable connections. Look for cracked or broken insulation, broken or loose clamps, or any corrosion that may be building up under the cable insulation.

Corrosion that builds up under cable insulation will show up usually near the terminal end as a slight bulge under the insulation.

Any cable problems can make even a good battery inefficient and also can affect the type of charge that the battery receives.

GENERAL MAINTENANCE INSTRUCTIONS

TRANSAXLE

CAUTION: Replacement axles are shipped to the dealer without lubricant. Follow lubrication instructions below before operating.

Numbers in parenthesis () refer to parts shown on Parts List.

Numbers in brackets [] refer to tools in Tool Kit.

1. Tighten ten bolts securing housing (1) and (3), and three bolts securing motor to housing (3), after first two weeks of operation. Check periodically thereafter.
2. Maintain lubricant level in housing as prescribed in lubrication instructions below.
3. When servicing axle, use care not to score, mar, or deface surfaces which come in contact with seals or bearings.
4. Prevent dirt, dust, or any foreign matter from getting into the axle housing when the motor, filler, check, or drain plugs have been removed.
5. When working on internal parts of axle, prevent damage to bearings by pressing against the inner race only to remove or install. ("Press" indicates the use of an arbor press, or similar device to force an interference fit). Bearings must be properly aligned to press straight. Use clean tools with clean hands to keep bearings clean. Replace damaged bearings to insure trouble-free operation.

LUBRICATION INSTRUCTIONS

1. Remove filler plug (2) from gear box. Through filler plug hole, add lubricant: SAE 90-EP (approximately 11 oz.). Replace filler plug and tighten.
2. Drain original lubricant from axle after 1,000 miles use and refill as in paragraph 1. (Note - two drain plugs (43) and (44) are located at the bottom of the axle housing. Remove plug located at the very bottom and filler plug (2) to drain lubricant. Drain and refill after each 12 months operation thereafter. Be sure the drain plug is reinstalled.

SERVICE INSTRUCTIONS

1. TO REMOVE SEAL ON SPEEDOMETER SHAFT

- a. Remove speedometer adaptor and plate.
- b. Clean dirt from around seal (26). Insert tip of seal puller [69] under seal lip, twist out by bearing shank of tool against casting, push down on handle as shown. (Fig. 1).

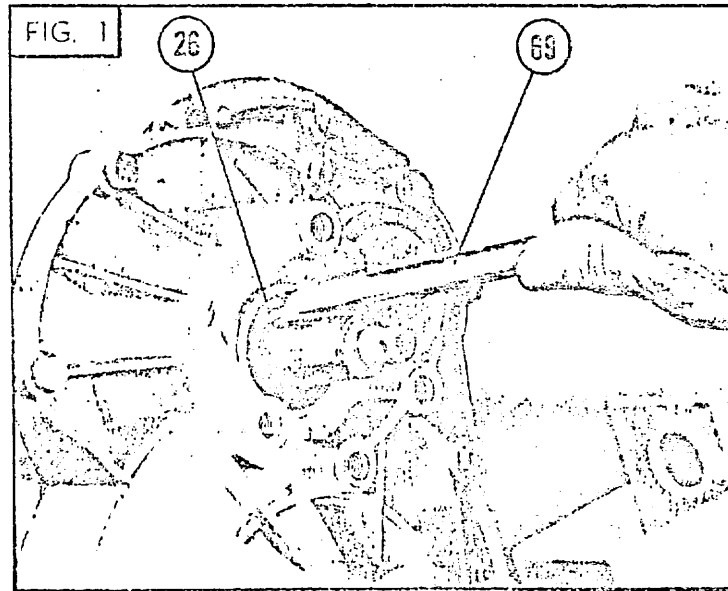

2. TO REPLACE SEAL

- a. Lubricate the rubber seal lips. Carefully push new seal insert tool [35] with the seal lip turned as shown (Fig. 2).

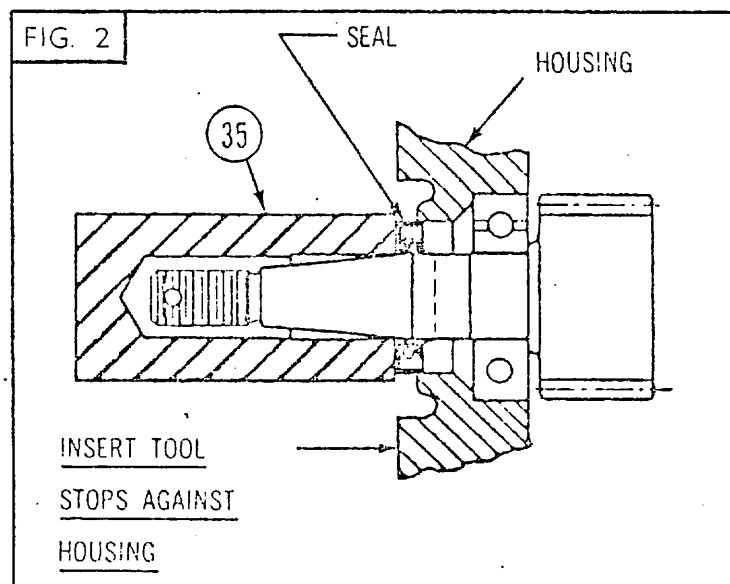

- b. Clean and deburr edge of housing bore. (Break sharp edge).
 - c. Place insert tool [35] over shaft and push insert into housing until tool touches housing.
 - d. Remove insert [35] with a twisting motion.
3. TO REMOVE AXLE SHAFT (13) and (16) OR AXLE SHAFT BEARING (12) - FOR SHAFTS HAVING INTEGRAL WHEEL PLATES.
- a. Remove retainer ring (19) using pliers [37].
 - b. Remove axle (13) and (16) with bearing (12) by pulling from axle tube.
 - c. Use bearing plate [79] inserted between bearing and wheel flange plate and press bearing and bearing safety ring from shaft.
- CAUTION: Do not reuse old bearing after removing - replaced with a new bearing.
4. TO REPLACE AXLE SHAFT (13) and (16) OR AXLE SHAFT BEARING (12)-- FOR SHAFTS HAVING INTEGRAL WHEEL MOUNTING PLATES.
- a. Clean bearing seat of axle to be installed.
 - b. Using suitable pipe against bearing inner race, press new bearing (12) on to shaft (13) or (16) until bearing seats firmly against shoulder. Use arbor press, if available.
 - c. Again using pipe, force bearing safety ring firmly against bearing inner race.
 - d. Insert shaft (splined end first) into housing (1) or (3) and gently rotate shaft to align shaft splines with splined bore of differential side gear and push shaft into position until bearing (12) seats against shoulder in axle tube.
 - e. Replace retainer ring (19) in axle tube with pliers [37].
- CAUTION: Be sure retainer ring is seated properly in groove.
5. TO DISASSEMBLE AXLE UNIT
- a. Drain lubricant from gear box per Paragraph 2, Lubrication Instructions.
 - b. Remove 6 hex head screws (5) and 4 hex screws (7) securing housings.

- c. Separate housings by pulling apart in a straight line.

NOTE: Dowel pins (1) located top and bottom of housing (3) resist separation unless pulled in straight line. Use care in prying housing apart so that gasket is not damaged or the mating housing surfaces defaced.

- d. With the housings apart gently remove motor pinion and bearings (29) (47) (48) and intermediate shaft assembly (27) (28) (46).

NOTE: The following work can best be done with the entire assembly placed on a bench or table edge and sitting on motor with axle tube vertical.

- e. To remove bearing from motor pinion (29) insert bearing plate [79] between gear teeth and bearing (48). Using push rod [78] press bearing from pinion.

CAUTION: Do not reuse old bearing after removing - replace with new bearing.

- f. Press bearing (47) from pinion in like manner.

- g. To remove intermediate gear (30) and bearing (27) from pinion shaft (28), press pinion (28) from gear (30). (See Fig. 3).

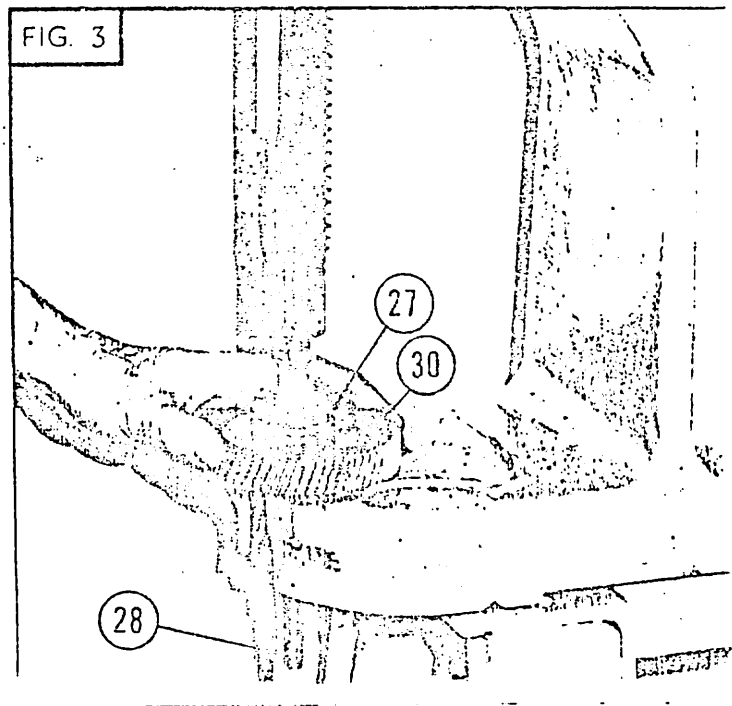

- h. To remove remaining bearing (27) from pinion (28), insert bearing plate [75] between gear and bearing, and press bearing off. Use correct push cap [65] or [66].
- i. To remove differential unit from housing, grasp unit and pull straight out.
- j. To disassemble differential gear assembly from the cage, push out roll pin (21) and differential pin (31). Rotate differential idlers (2) from cage and lift idlers free through cage opening. (See Fig. 4).

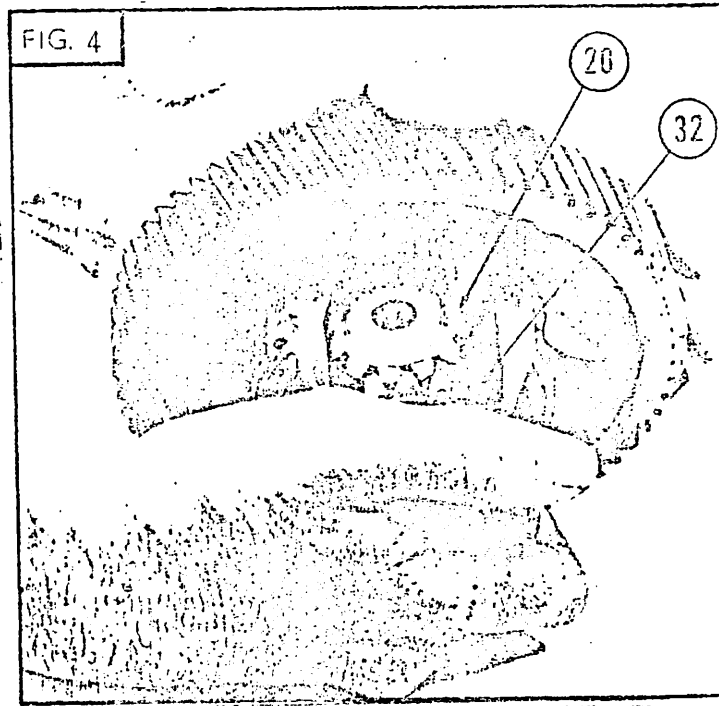

- k. Differential side gears (32) and thrust washers (41) may then be removed through the cage opening.
- l. To remove bearings from cage gear, use plug [33] and puller [36].

NOTE: To pull bearing adjacent to gear, locate notches on puller legs under bearing.

6. TO ASSEMBLE AXLE UNIT

Before reassembly of the axle, all parts should be inspected for wear or other damage. Worn or damaged parts should be replaced to avoid possible early failure in service.

Differential thrust washers and spherical washers (if used) should, particularly, be inspected visually for wear, scoring or slight cracks and should be replaced as indicated by this inspection.

Reasonable care should be used to keep dirt, trash and foreign matter out of the assembly as repair and assembly work is done. Bearings should be visually inspected and roll tested for rough spots before being reused. Rough bearings should always be replaced.

CAUTION: Housings should be carefully washed with varsol, wiped clean and dry before starting assembly.

- a. Press bearings on cage gear (15) using sleeve [77].
- b. Replace differential side gears, thrust washers, idler gears, spherical washers, pin and roll pin per Paragraphs 5 j. and k. in reverse.
- c. Press intermediate gear (30) on pinion (28) using pinion end of sleeve tool [34]. Be sure key (40) is in place.
- d. Press bearings (27) in place on pinion using pinion end of sleeve tool [34].
- e. Insert seal protector [35] through seal in housing from outside. Push pinion assembly into housing until bearing is inserted into housing bore 1/4 inch. Differential gear must go under intermediate gear (30).
- f. Push differential unit into housing (1). Push pinion assembly and differential gear alternately to seat in housing.
- g. Put gasket (4) in place. Gasket must be clean, free of tears and lay flat against gasket faces of housing.
- h. Push housings together aligning dowel pin (8). Push in straight line.
- i. Replace 6 hex head screws (5) and 4 hex head screws (7) torque to 8-10 foot pounds.
- j. Add lubricant per Paragraph 1, Lubrication Instructions.

TRANSAXLE PARTS

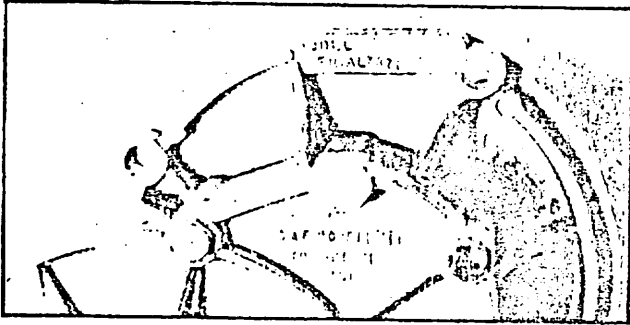
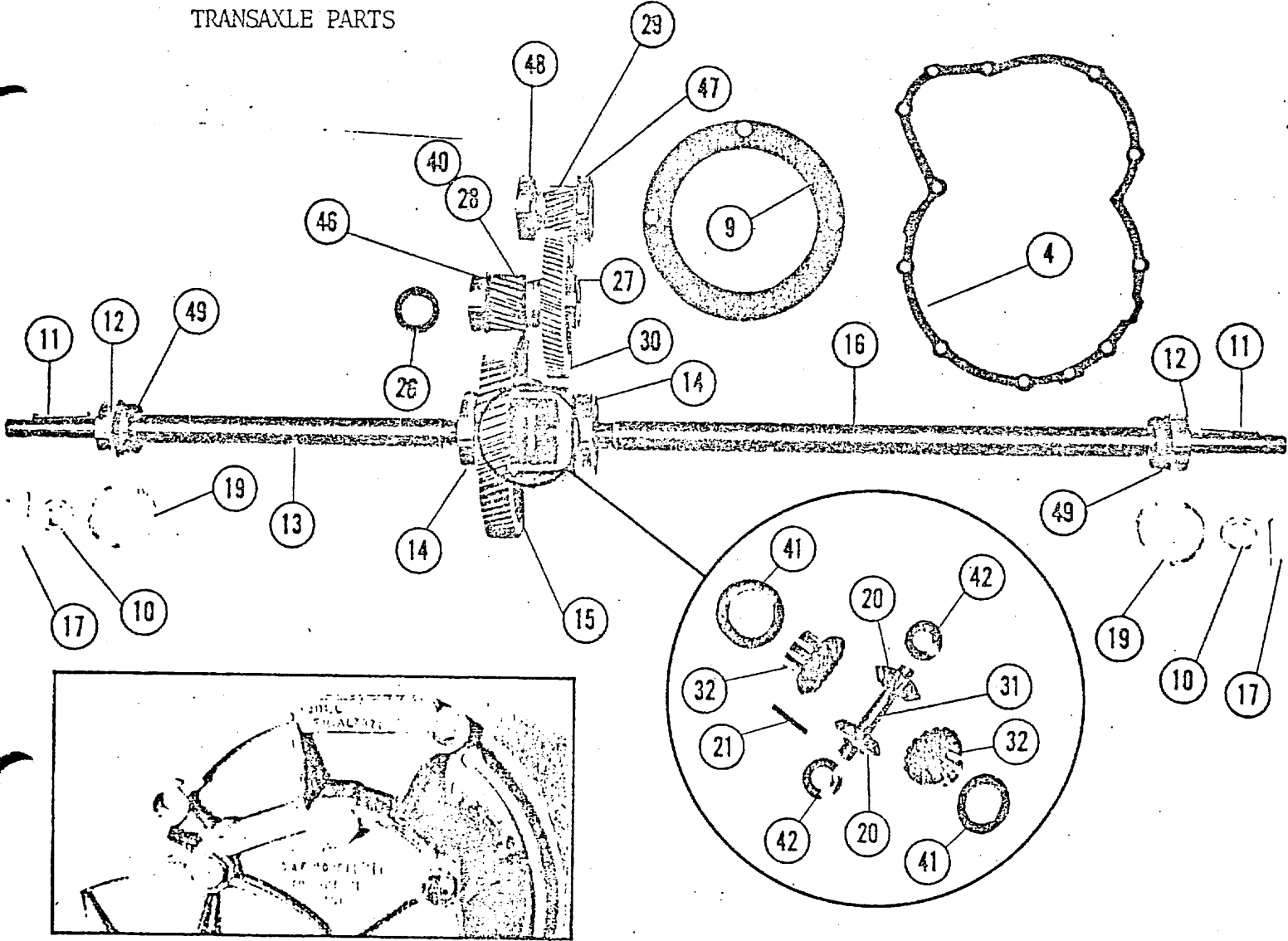

NOTE:
 Items 10, 11, 17 not used.
 Integral Hub/Axle used on
 all models.

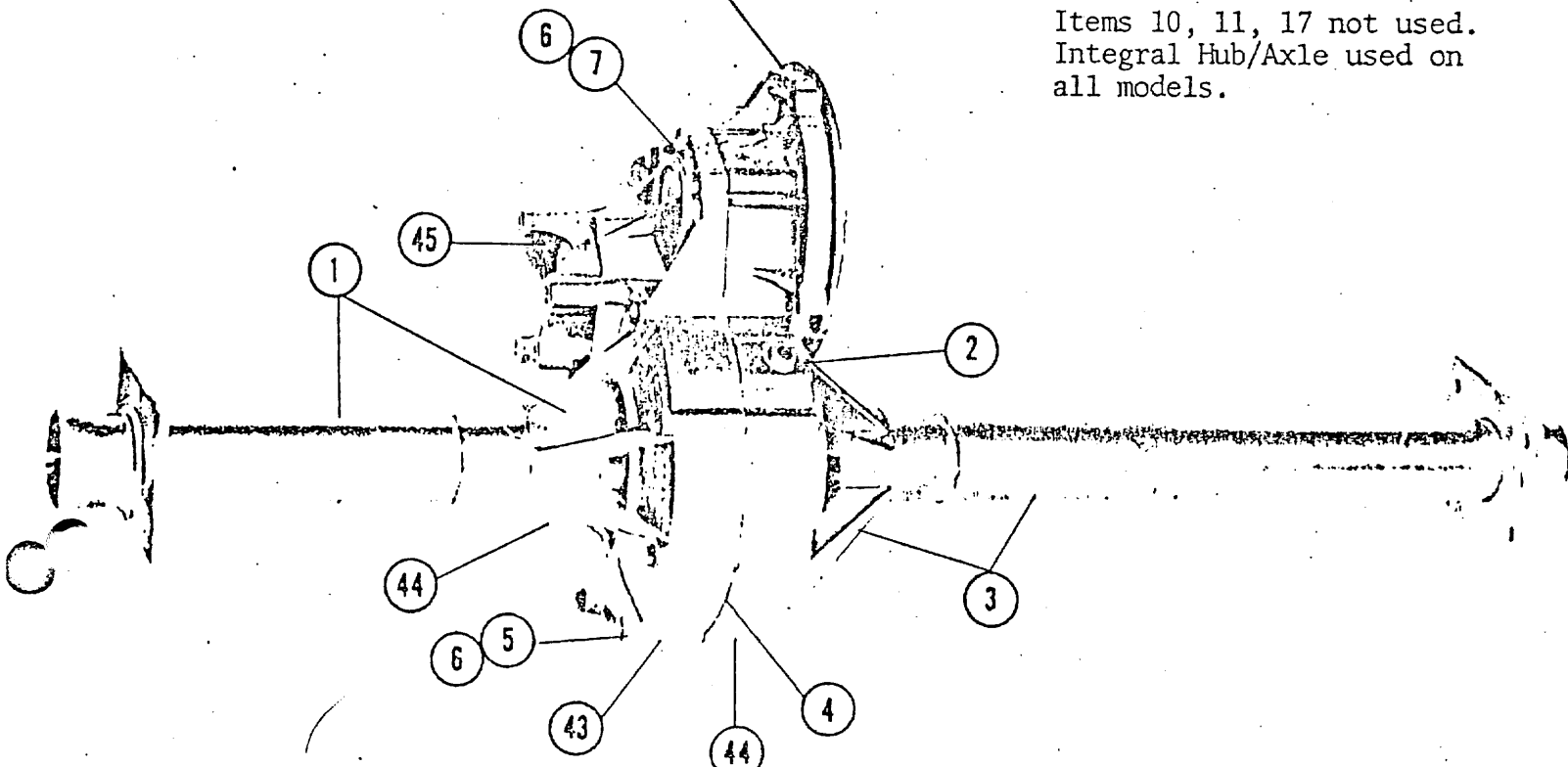

TRANSAXLE PARTS LIST

<u>ITEM NO.</u>	<u>DESCRIPTION</u>	<u>NUMBER REQUIRED</u>	<u>PART NUMBER</u>
1	Housing Assembly, L.H. - includes Tubes	1	10201
2	Fill Plug	1	10202
3	Housing Assembly, R.H. - includes Tubes	1	10203
4	Housing Gasket	1	925
5	Hex Hd. Cap Screw	6	10204
6	Lockwasher	10	10205
7	Hex Hd. Cap Screw	4	10206
8	Dowel Pin	2	10207
9	Motor Gasket	1	5743
12	Bearing - Axle Shaft	2	10208
13	Axle, L.H.	1	5700
14	Bearing - Differential Carrier	2	10209
15	Output Gear & Cage	1	10210
16	Axle, R.H.	1	5699
19	Retaining Ring	2	10211
20	Differential Idler Gear	2	Part of 10212
21	Roll Pin	1	Part of 10212
26	Seal	1	10213
27	Bearing - Intermediate Shaft	1	10214
28	Intermediate Pinion	1	10215
29	Motor Pinion	1	10216
30	Intermediate Gear	1	10217
31	Differential Pin	1	Part of 10212
32	Differential Side Gear	2	Part of 10212

Continued

TRANSAXLE PARTS LIST (CONTINUED)

<u>ITEM NO.</u>	<u>DESCRIPTION</u>	<u>NUMBER REQUIRED</u>	<u>PART NUMBER</u>
40	Key (Not Shown, use Hardened Alloy Steel only)	1	10218
41	Thrust Washer	2	Part of 10212
42	Spherical Washer	2	Part of 10212
43	Drain Plug, Magnetic (Not Shown)	1	10219
44	Plug - Check or Drain	2	10220
46	Bearing - Intermediate Shaft	1	10221
47	Bearing - Pinion	1	10222
48	Bearing - Pinion	1	10223
49	Seal - Axle Shaft	2	5698

TOOL KIT

To assist Sebring-Vanguard dealers in easy maintenance, the axle manufacturer has developed a Service Tool Kit. This Kit is available on special order through the Sebring-Vanguard Parts Department.

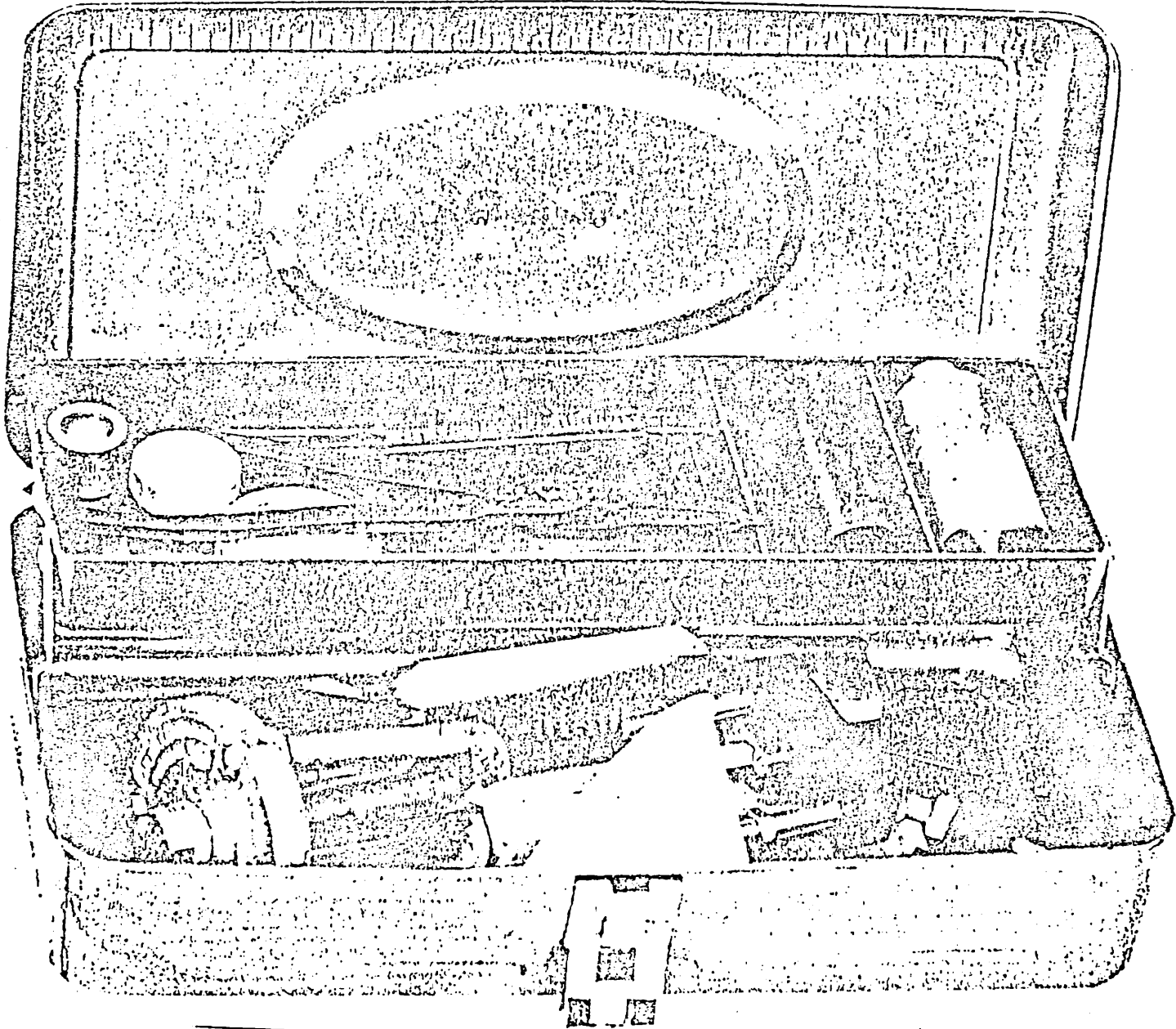

MODEL 25 TRANSAXLE TOOL KIT

<u>Part No.</u>	<u>Name</u>	<u>Part No.</u>	<u>Name</u>	<u>Part No.</u>	<u>Name</u>
33	Plug	66	Push Cap	72	Cap
34	Sleeve Tool	67	Puller Wrench	74	Insert Tool
35	Insert Tool	68	Puller	75	Bearing Plate
36	Puller Wrench	69	Seal Puller	77	Sleeve
37	Pliers	70	Funnel	78	Push Cap
65	Push Cap	71	Allen Wrench	79	Bearing Plate

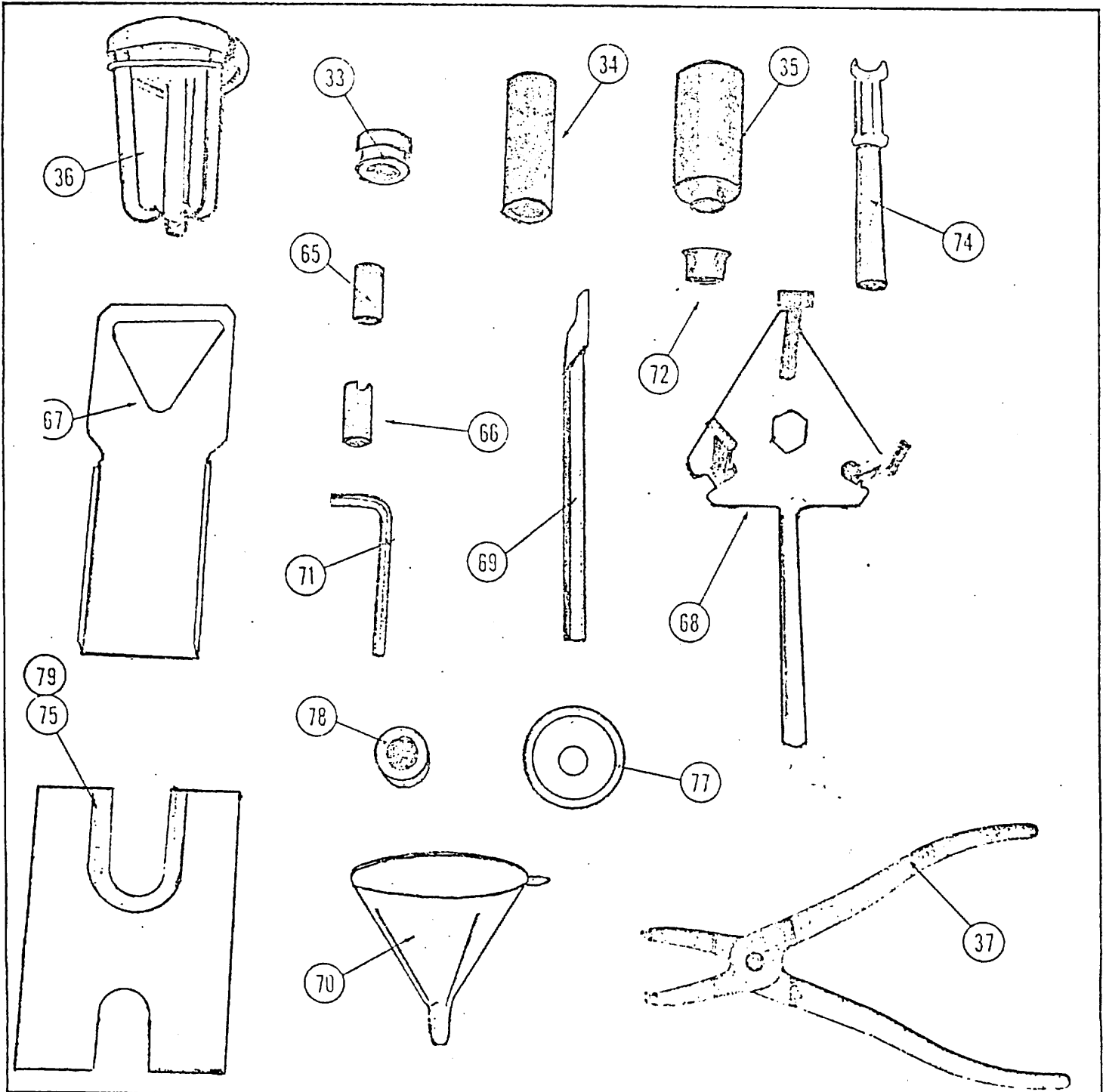

3-1/2 HP GENERAL ELECTRIC MOTOR

ROUTINE EXAMINATION AND BRUSH REPLACEMENT

1. At 3,000 miles or six months, remove the covers over the brush access openings and examine the interior.
 - a. Make sure the brush shunts are positioned so they can move freely down the brush holder slot as the brush wears, and remove any obstruction which may have occurred since the last inspection which might cause the brush to bind in its holder.
 - b. Check each brush for free movement in its holder and examine it for wear and general condition. If a brush is broken, cracked, severely chipped, or worn to a length of less than 5/8 inch measured on the short side of the brush, replace it. Whenever any brushes are replaced, it is good practice to replace all of them. Keep extra brushes on hand. It is recommended that only brushes obtained from General Electric Company be used.
 - c. Examine the condition of the brush springs. Make sure the spring coils are uniform and the springs do not appear discolored which could indicate heating that has caused loss of spring quality. If these or other signs of spring damage are evident, replace the spring or use a small spring scale to see if the spring requires one pound or more force to lift it at the point of contact with the worn brush. *check*
 - d. Observe the condition of the commutator and the armature coils which may be visible. Refer to section entitled, "Inspection of Armature" for details to look for during this inspection.
2. Brush Replacement
 - a. With fingers or a suitable hook, lift the brush spring end up so the brush may slide up out of its holder, loosen the brush screw to remove the brush shunt terminal and remove the brush.
 - b. Again, lift the end of the brush spring and place the new brush in the holder in the same relative position as the old brush removed. Place end of spring in position on top of brush. Connect the brush shunt terminal to its proper crossover with the brush screw. Note that the position of the brush shunt is important when installing brushes. Assure positioning to permit the brush shunt to travel down the brush holder slot as the brush wears. If it hangs up, commutator damage and motor failure will result. Install the brush like the sketch below and observe if the shunt

will follow down the slot with wear. Make minor adjustments to make sure the path of movement will be free before final tightening of the brush screw to make a firm, secure connection. Also make sure that only the insulated portion of the shunt touches the motor endshield or is touched by the brush cover when it is reinstalled.

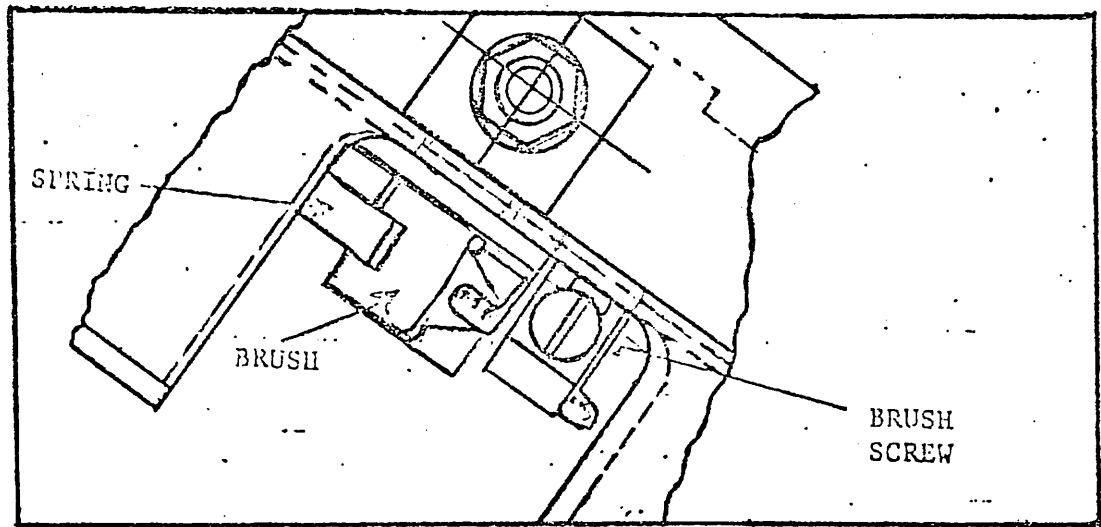

c. Replace the covers over the brush access openings.

3. Cleaning

At regular maintenance periods for the vehicle, remove the cover over the brush access openings and remove all foreign material, such as dirt and carbon dust, from the motor interior with dry, compressed air of moderate pressure. Clean by suction, if possible, to avoid blowing dirt, carbon dust, or metal particles into the bearings and insulation.

4. When parts have worn considerably, the motor interior is very dirty, or other indications suggest a higher echelon of maintenance, the motor must be disassembled.

DISASSEMBLY (AFTER ANY ATTACHMENTS HAVE BEEN REMOVED FROM THE MOTOR)

1. Smooth away any signs of roughness or burrs from the shaft.
2. Remove brush access covers.
3. With fingers, or suitable hook, lift the end of the brush springs and lift the brush by its shunt so that the spring can be released against the side of the brush to hold it free from the commutator.
4. With light chisel mark spanning the joint between the endshield and stator identify exact relationship of these parts for later re-assembly reference.
5. Remove the two clamp screws at each end of the motor which hold the close fit rabbeted endshields to the stator.
6. Provide some suitable covering on the shaft to protect the shaft seal lip and coat it and the seal lip with bearing grease. Carefully remove the pulley endshield. Note exactly the arrangement and location of spring and spacer washers for reassembly use later.
7. Remove the stator assembly, being careful to thread the thermostat leads free from the endshield in the process. When necessary to change field coils, the old ones can be removed by removing the terminal nuts and pole piece screws from the stator. Note that the old or new thermostat must be glass-cloth taped and cemented with LEEBOND #12-78 epoxy adhesive (Leepoxy Plastics, Inc., Ft. Wayne, Indiana) or equivalent, to the new coil in the same location as on the original before reassembly into the stator.
8. Remove the armature.
9. When necessary, the commutator endshield may be further disassembled to change brushes, brush rigging, and cross-over leads by removing the appropriate and obvious screws. This should be done if the brush holders or insulation plate appear burned, warped or have loosened rivets.

INSPECTION OF ARMATURE

1. If deep burned sections are evident on the commutator bars, this is a symptom of an open circuit in the armature winding. If such evidence is noted, measure the armature resistance by selecting at random any two bars of the commutator with a bar span of 1-10.

NOTE: This condition could be caused by an undetected fault of manufacture appearing early in normal field service conditions, or it could be caused by overloading of the motor causing high temperature failure of connections. The resulting high resistance in a joint could cause this symptom appearance. Evidence of general overheating accompanying flat spots would tend to indicate overworking of the motor.

2. If one or more armature conductors are abnormally black or appear burned compared with the other armature conductors, this is an indication of shorted armature winding. If such evidence is detected, a dirty armature should first be blown off to clean it and then checked with a growler. If the short circuit is not confirmed by this indication, check resistance and apply a high potential test not exceeding 600 volts AC for 1 minute, If the armature does not pass these tests, it should not be used.

NOTE: Short circuited coils can be caused by many things, as well as an undetected manufacturing fault which most likely would show up early in normal service.

3. If a generally heat discolored appearance uniformly over the commutator or windings is observed, it is usually a sign of overloading of the vehicle or motor. This should be corrected or the symptoms will be repetitive and motors will be burned out frequently. While an armature of this appearance might pass checks for resistance, shorts, and high potential, it has lost some survival ability and will not have a normal service life.
4. Bubbled insulation and individual brush burn marks on the commutator is rather a classic example of a motor armature which has been loaded up to stall with power applied. It promptly overheated and its elements boiled to quick failure. Other comments are similar to 3 above.

In general, armatures with other than normal service wear are not recommended to be repaired and reused although some re-soldering of commutators in the field has been successfully done. Replacement is suggested as the best means for maintaining the integrity of these heavy duty motors which sometimes run at high speed under light load conditions.

5. Commutator Inspection and Care

- a. Inspect the commutator during each brush inspection.
- b. Commutator bars should not be pitted, burned or grooved in the brush track. If found in this condition, the surface should be

refinished in a lathe, limiting the depth of cut to .005 inch or less on a side and repeat until smooth.

Before a final cut, the mica insulation between commutator bars should be undercut .032 inch and no mica slivers should be left along the side of the bars above the undercut.

Next, dynamic balance the armature to within .0015 inch amplitude at 3000 RPM. After this, the final finish cut should be made with a diamond tool to obtain a surface finish of 8 to 16 micro inch. The armature should not be put back in service with a diameter of less than 2.625 inches.

- c. After refinishing a commutator, check it for eccentricity. It should not exceed .001 inch total indicator reading for the entire diameter and with a .0002 inch maximum bar-to-bar difference.

INSPECTION OF FIELD WINDINGS

If, upon inspection, the insulation on the field coils appears blackened or charred, the serviceability of the coils is questionable. Burned or scorched coil insulation is a symptom of coil overheating due to overloads, grounded, or short circuited winding.

To check the windings electrically for grounds or open circuits, a continuity tester, ground tester, and ohm meter are required.

To check for a grounded field connect the tester between terminal studs S1 to ground and S2 to ground.

To check for an open or shorted winding: Connect the ohm meter between S2 and S1. The resistance should read .0138 plus or minus .0014 ohm.

BEARING INSPECTION AND CARE

1. The bearings are prelubricated with Chevron SRI-2 high temperature grease, or equivalent (do not use silicone grease in a DC motor), sufficient for the life of the bearings.
2. Check bearings by turning them with your fingers. Feel for binding or gritty effects and for excessive looseness or wobble. If any defect is apparent or if there is any doubt at all as to serviceability of the bearings, replace them with new ones.

3. Pull the old bearings by means of a suitable bearing puller. Press new bearings into place by means of an arbor that exerts pressure on the inner ring. Do not use a hammer for bearing replacement. It will damage the bearing.

REASSEMBLY

1. Set commutator endshield in place on bench with brush rigging facing upward.

Push each brush back up into brush holder until its end would permit commutator to pass under without hitting. Adjust end of spring so that it is against side of brush and holds brush in "cocked" position.
2. Set armature, with the ball bearings already assembled, into place in the endshield.
3. Push on end of each brush to release onto the commutator. Observe that brushes seat on commutator properly and that end of springs ride on brush tops in line with brush holder grooves. Make sure that the brush shunt will travel down the holder slot as the brush wears.
4. Mount the stator over the armature and position it exactly with chisel mark on endshield. Thread thermostat leads through the proper hole in the commutator endshield. Gently seat on rabbet.
5. a. The pulley endshield contains a seal whose inside lip rides on a highly finished surface of the shaft. If the shaft surface is still polished and undamaged but the seal requires replacement then:
 - (1) Drive the seal from the pulley endshield with a suitable punch and hammer.
 - (2) Apply "Hanna Oil Sealer" to the mating surface before placement of the oil seal (Use #709957 Oil Seal Compound - Hanna Paint Company, Columbus, Ohio, or equivalent). Do not allow to dry before assembly.
 - (3) Press seal into position with a suitable press so that its outside diameter is flush with the face of the endshield surface recess (see motor outline). Locate seal into the pulley endshield with the seal lip spring facing away from the bearing.

- b. Position spring, spacer, and shim washers into the pulley endshield using enough Chevron SRI-2 grease in the cavity to hold these parts in place. After suitably covering the spline of the armature shaft to prevent damage to the seal lip (also use bearing grease to coat seal lip and shaft cover surface), gently fit the endshield assembly over the shaft and pulley end bearing. Line up chisel marks and seat the endshield into the stator rabbet.
6. Be sure endshields are snugly fit in stator rabbets, then replace clamp screws on both ends. Check to determine that armature is free to turn. If it will not turn, the parts have been assembled to cause binding.
7. Replace brush access covers.
8. Make a high potential test (up to maximum of 600 volts AC for 1 minute) to assure motor has been properly reassembled.
9. If a running performance test is to be made before reinstalling motor in vehicle, observe caution that this series motor will overspeed if voltage is applied under no load or inadequate load conditions. Do not apply voltage to the motor unless a torque load equivalent to 3-1/2 HP at 3200 RPM is first connected to the shaft, and use only direct current battery power.

LIGHT BULB CHART

Headlamps	6012
Parking Lamps - First Design	1895
Parking Lamps - Second Design	1156
Turn Signal Front - First Design	1895
Turn Signal Front - Second Design	1156
Turn Signal Upper Rear, -If Equipped	1895
Turn Signal Lower Rear	1157
Stop & Tail Lamp	1157
Back-Up Lamp	1156
License Plate Lamp	67
Instrument Cluster - First Design	53
Instrument Cluster - Second Design - Must replace complete Switch or complete Indicator	
Radio Dial	1893
Courtesy Lamp	1003
Speedometer Lamp	53

FUSE CHART

Location

1	Voltmeter - Second Design Dash	10 Amp
2	Accessory	10 Amp
3	Light	20 Amp
4	Turn & Brake	15 Amp
5	Controller	15 Amp
6	Radio & Defroster	10 Amp
7	Empty	
8	First Design - Dash - Voltmeter - Horn - Wiper	20 Amp
8	Second Design - Horn - Wiper - Dash	20 Amp

INSTRUCTIONS FOR DEFROSTER

1. Mount defroster on windshield with epoxy glue 2" above bottom of windshield and 4" toward center from left edge with wire lead toward left.
2. Open door and drill 5/16" hole in left side of dash.
3. Insert wire lead from defroster until attached grommet is seated.
4. Drill two 9/64" holes in bottom of dash to the left of the fuse block. Use templet on diagram just below relay.
5. Cut one lead wire from defroster and attach to lower lug on relay.
6. Other end of cut should be attached to center lug on relay then fastened to fuse holder at right end of fuse block.
7. Balance of wire should follow wiring harness under the floor to the battery box.
8. Hook 2 wires up according to diagram.
9. Install relay under dash.
10. Run jumper wire from ignition switch to defroster switch.
11. Then from defroster switch to base of relay.
12. Ground other lug on relay switch.

SEBRING VANGUARD, INC

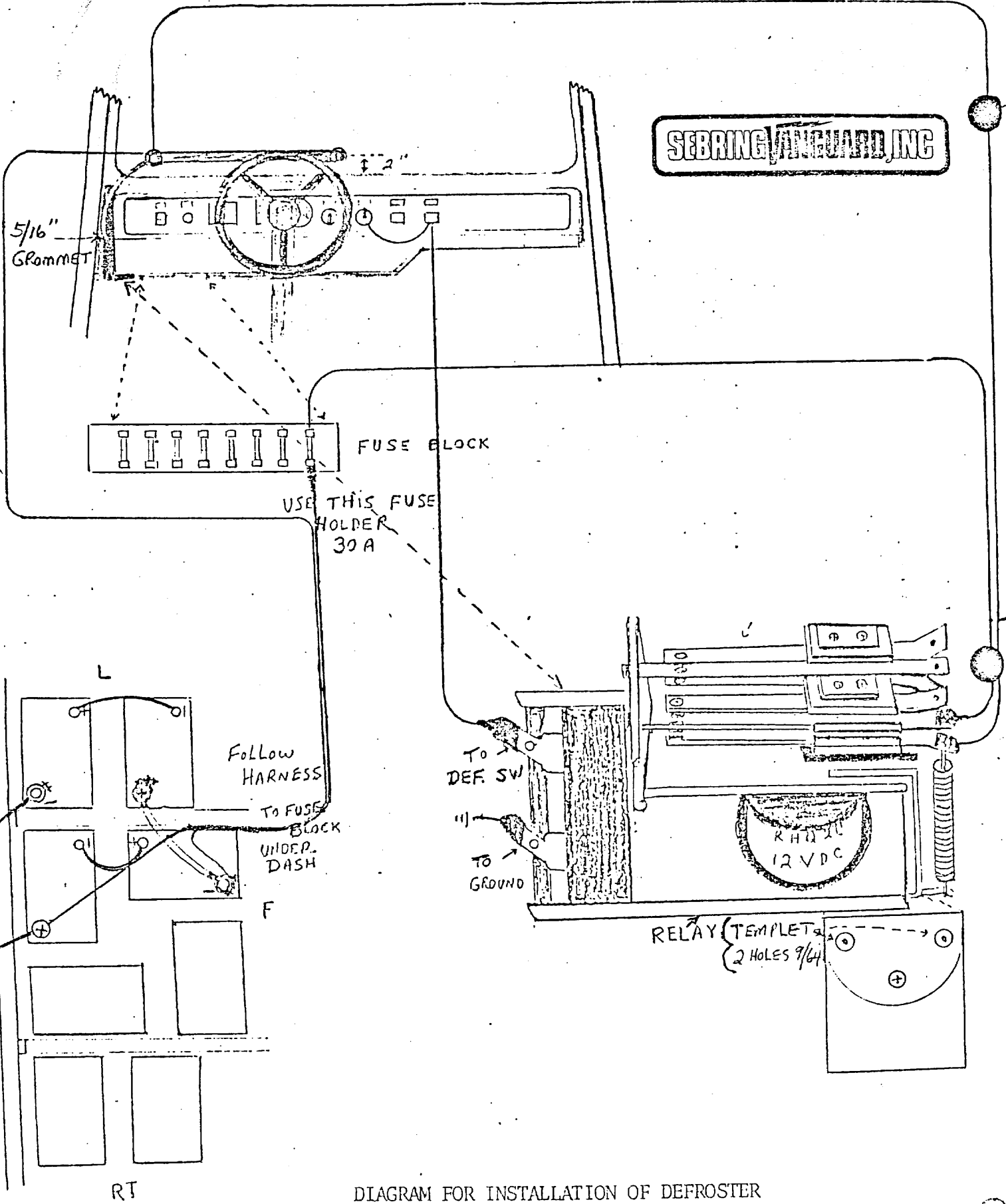
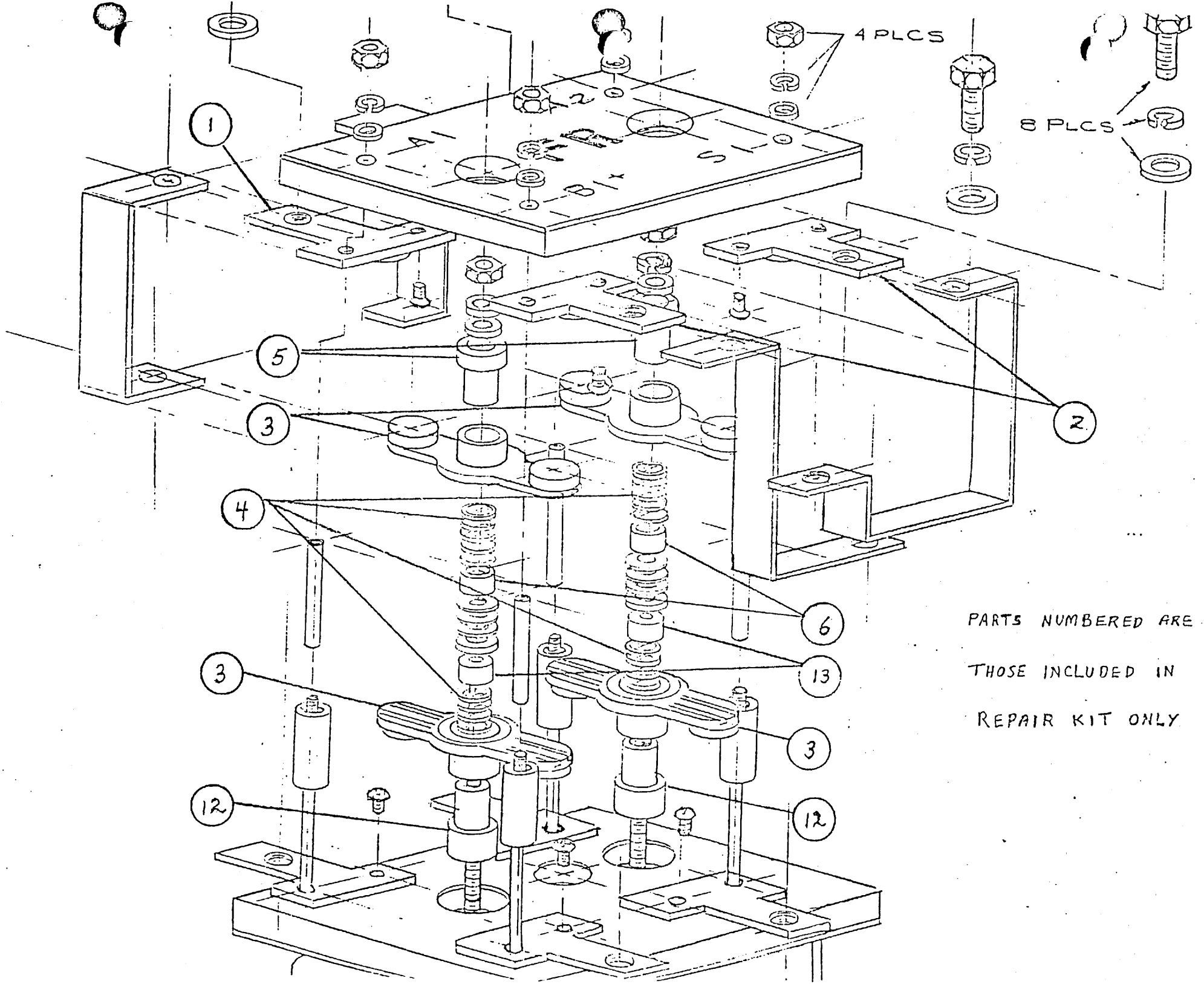
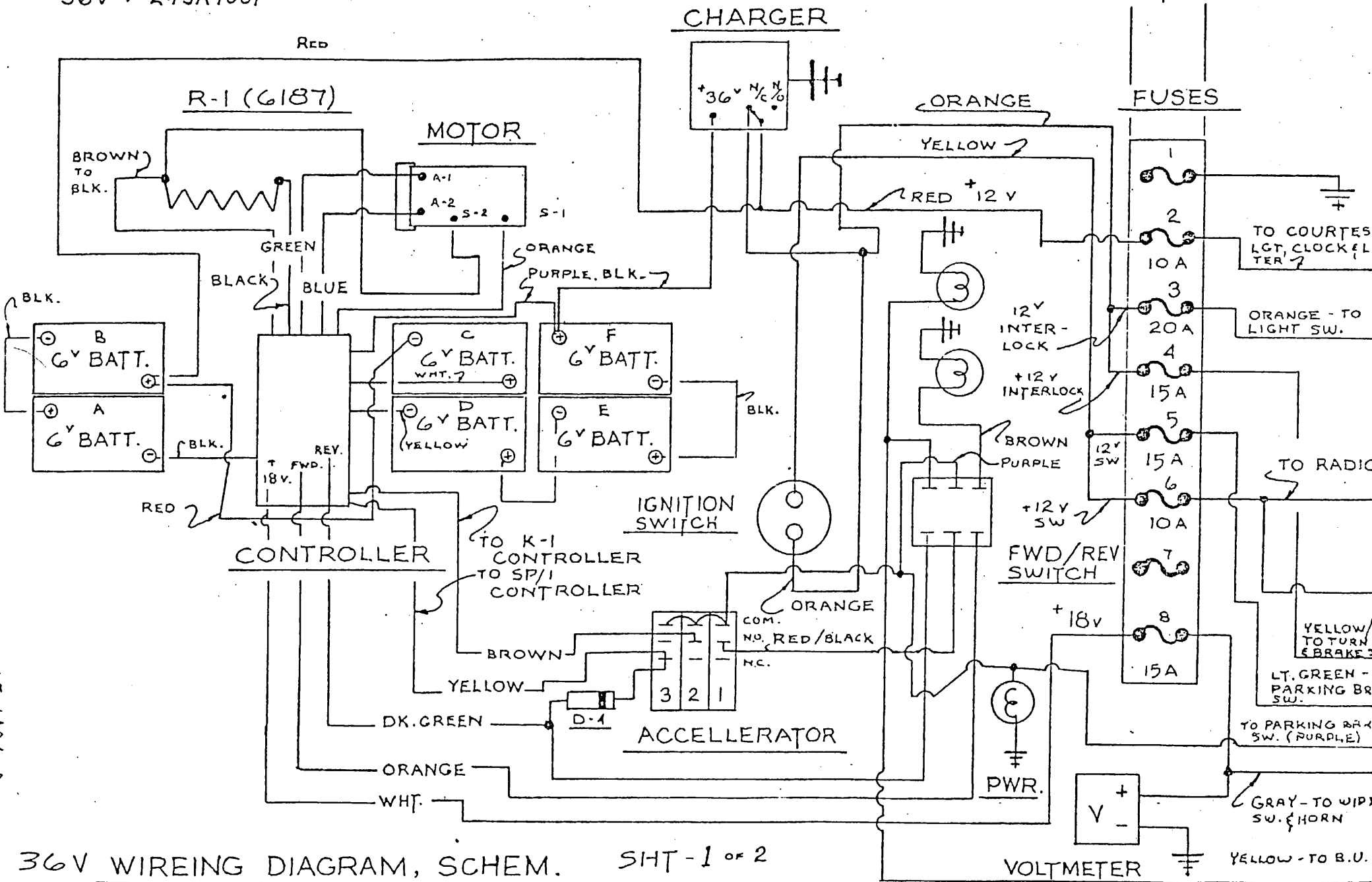

DIAGRAM FOR INSTALLATION OF DEFROSTER



PARTS NUMBERED ARE
 THOSE INCLUDED IN
 REPAIR KIT ONLY

36V : 245R1001-



36V WIREING DIAGRAM, SCHEM.

SHT - 1 of 2

VOLTMETER

YELLOW - TO B.U.

36V : 24SR1001-

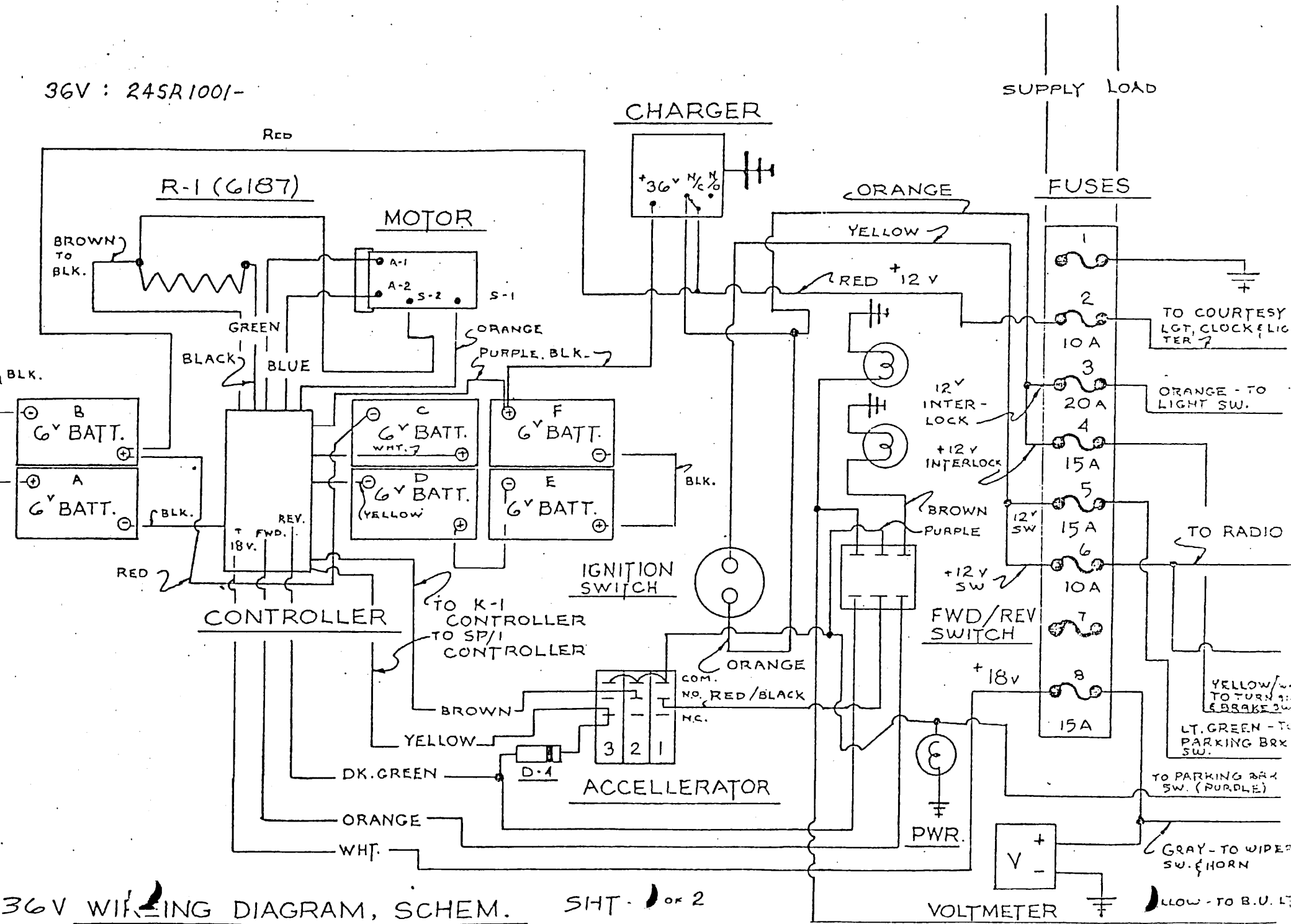

36V WIRING DIAGRAM, SCHEM.

36V : 24SR1001-
 SV48 : 24SR1001-

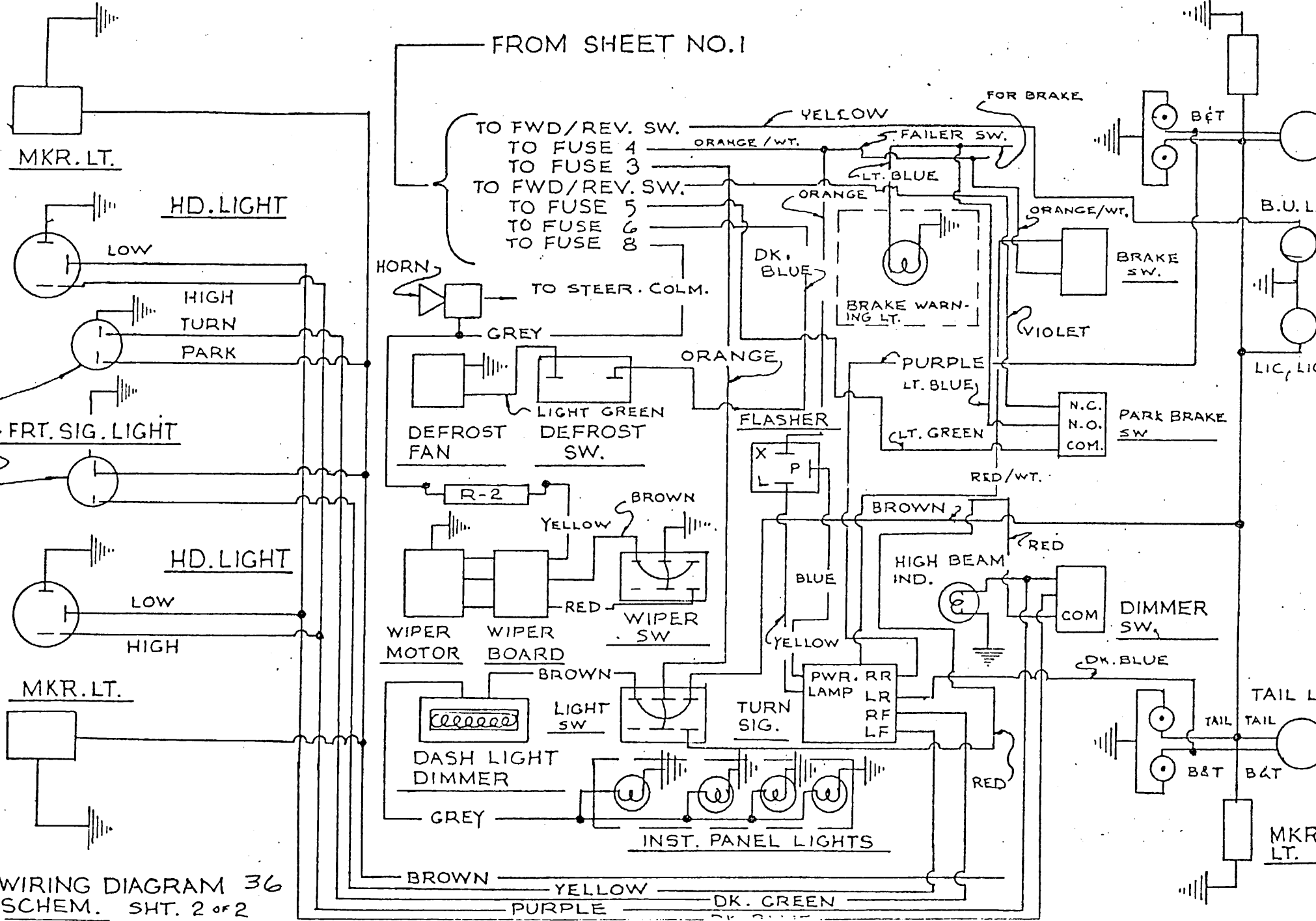

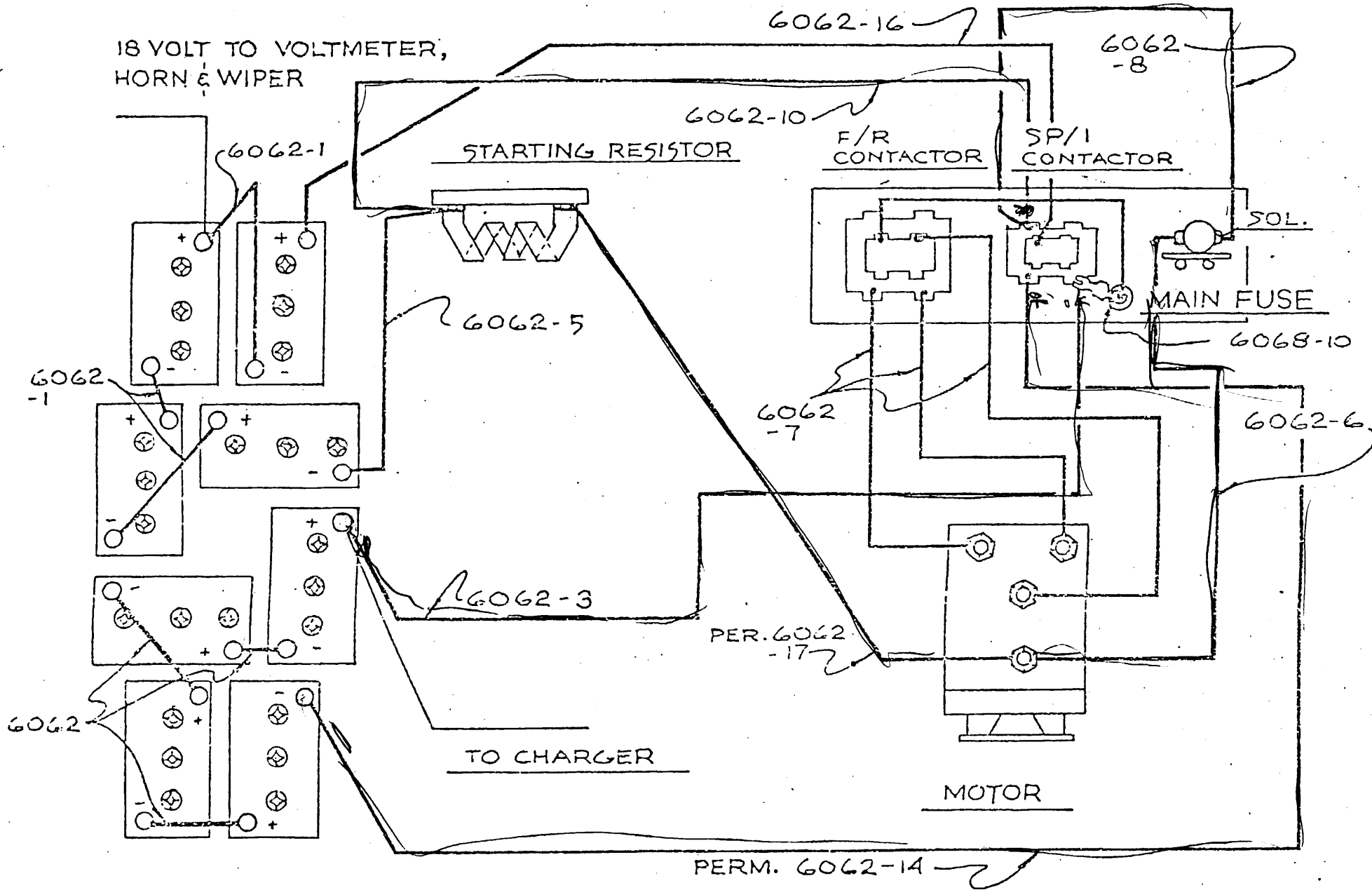

SV 48:124 SR1501

HIGH POWER WIRING DIAGRAM

SV-48

05-1022-A

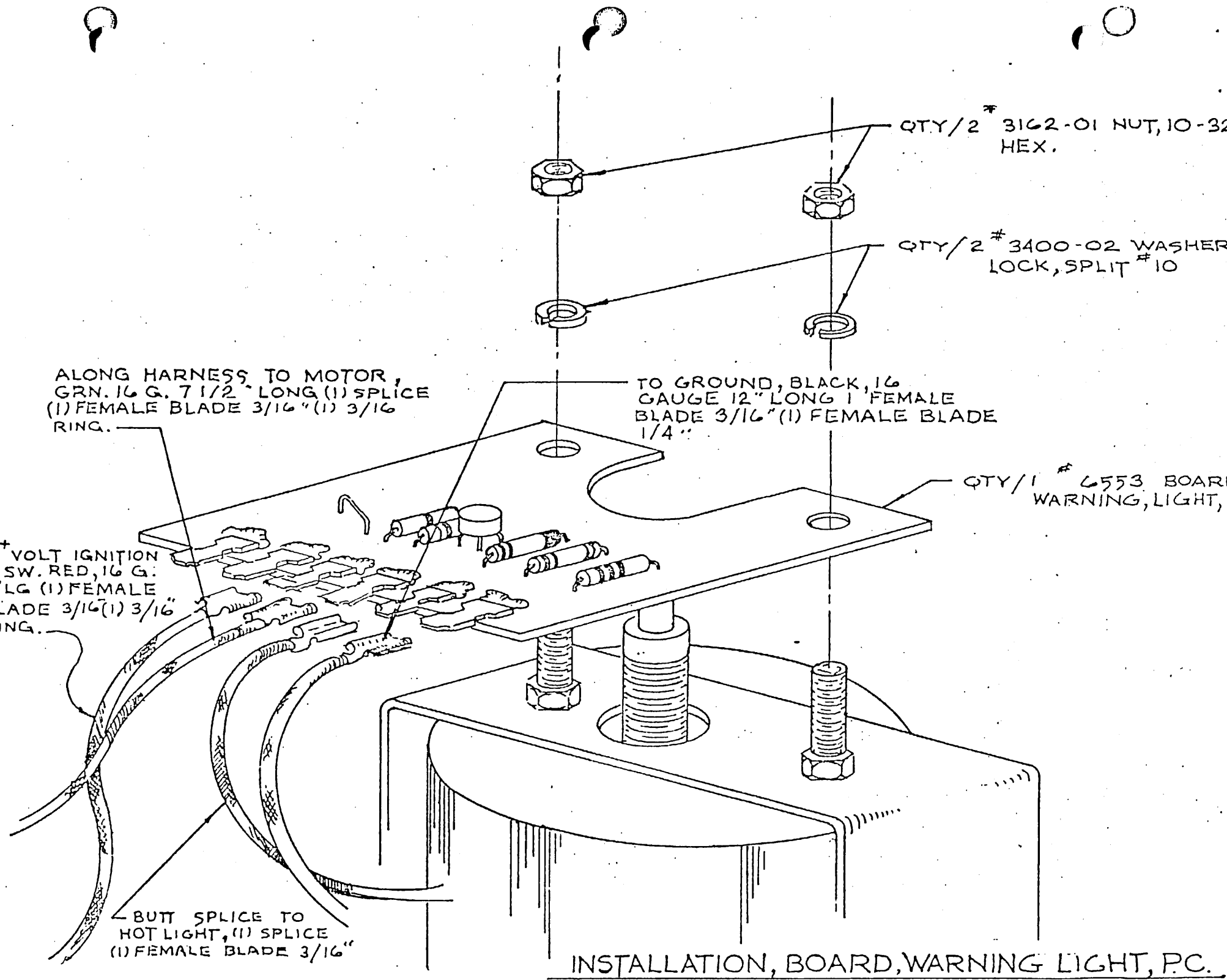

QTY/2 # 3162-01 NUT, 10-32 HEX.

QTY/2 # 3400-02 WASHER LOCK, SPLIT # 10

ALONG HARNESS TO MOTOR, GRN. 16 G. 7 1/2" LONG (1) SPLICE (1) FEMALE BLADE 3/16" (1) 3/16 RING.

TO GROUND, BLACK, 16 GAUGE 12" LONG 1 FEMALE BLADE 3/16" (1) FEMALE BLADE 1/4"

QTY/1 # 6553 BOARD WARNING, LIGHT, P.C.

12+ VOLT IGNITION SW. RED, 16 G. 5" LG (1) FEMALE BLADE 3/16" (1) 3/16 RING.

- BUTT SPLICE TO HOT LIGHT, (1) SPLICE (1) FEMALE BLADE 3/16"

INSTALLATION, BOARD, WARNING LIGHT, P.C.

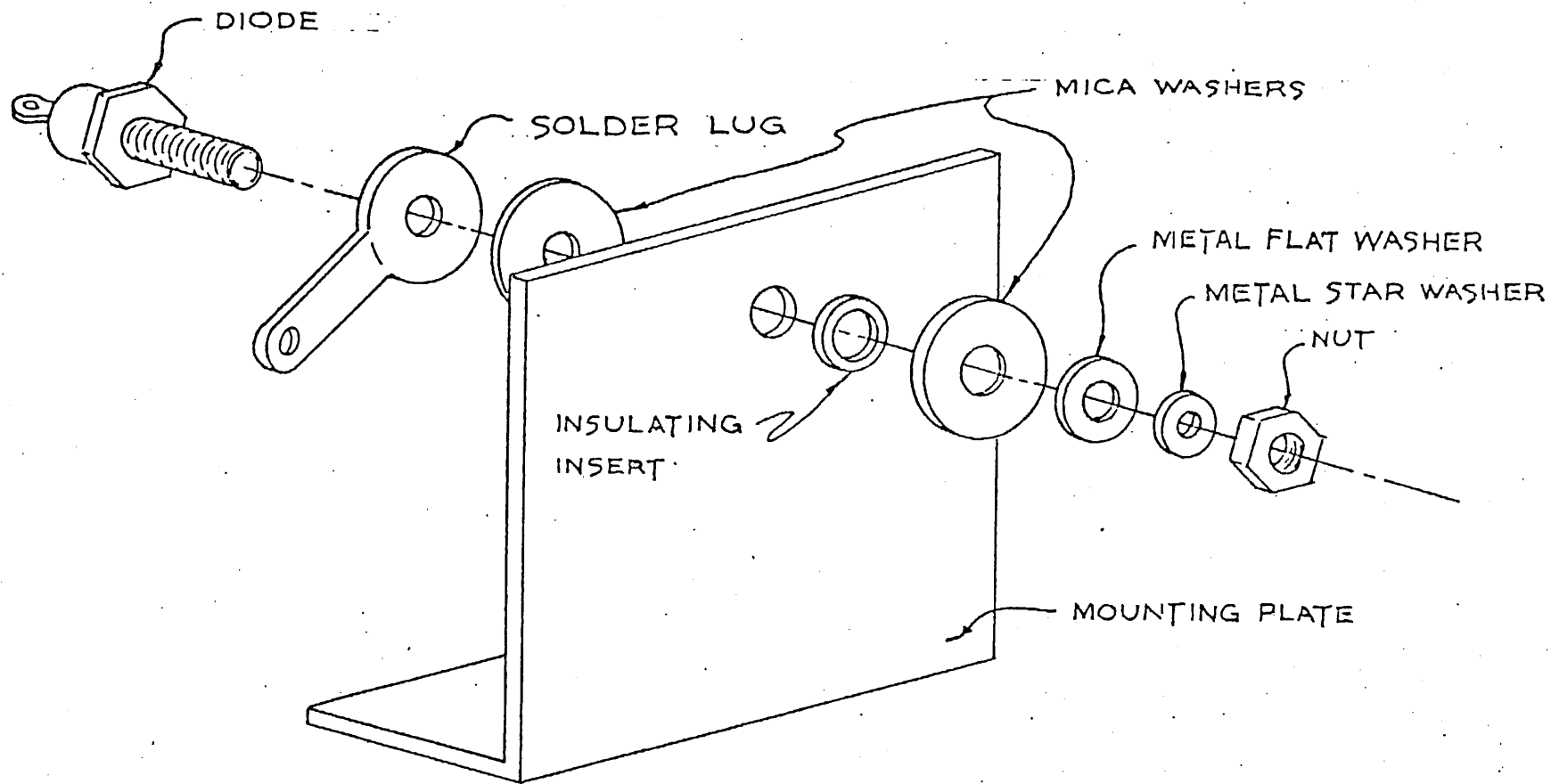

DIODE MOUNTING ASS'Y (KIT)

FORWARD ↓ REVERSE ↑

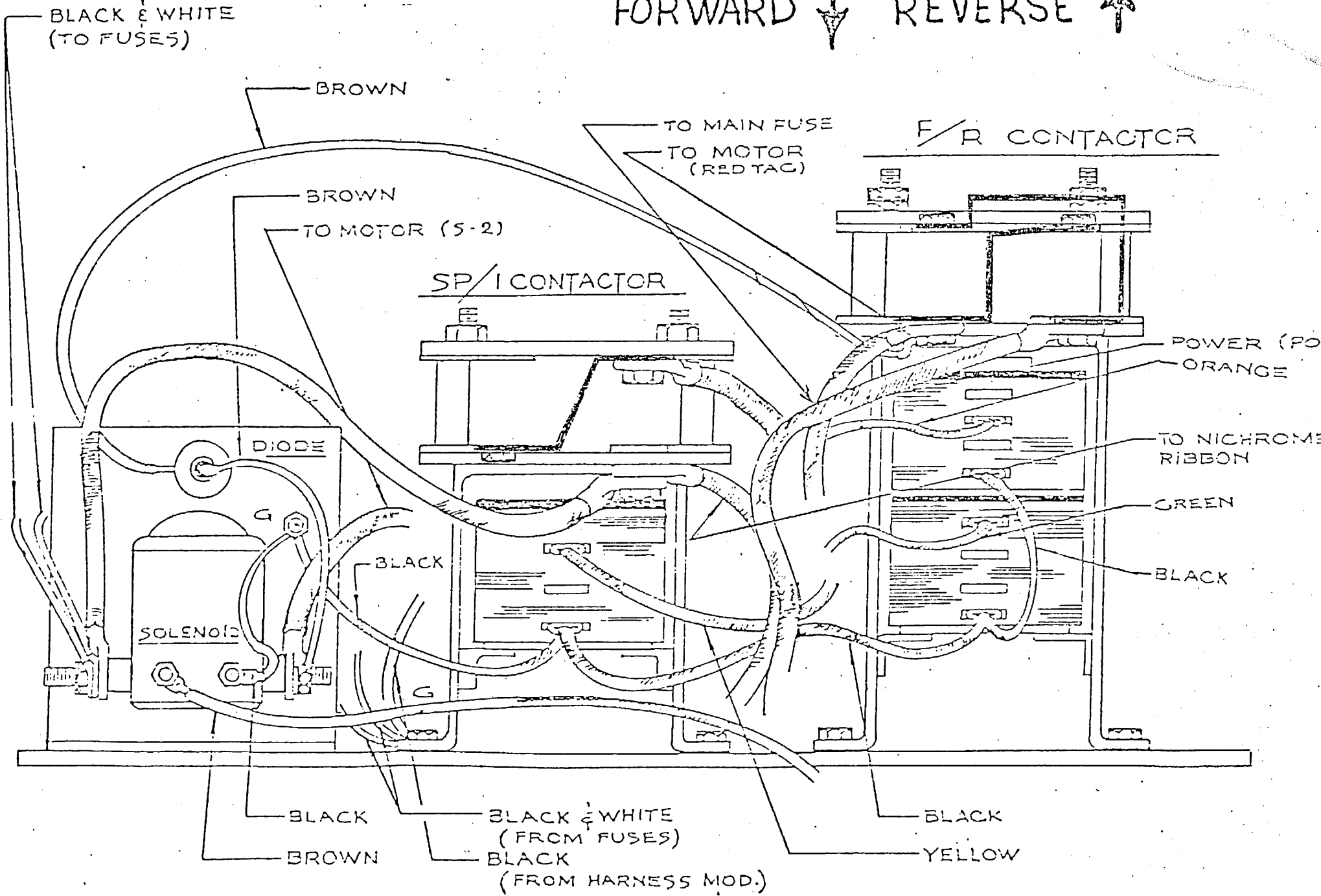

CONT. WIRING DIAGRAM, L/P

GENERAL NOTES

1. WIRE SPEC. SAE J558a TYPE SGT 4AWG INSULATION COLOR BLACK.
2. RING TERM. - SAE J561a FOR BATTERY CABLES.
3. BOLT & NUT TO BE 1/4-20 x 1/8 LEAD PLATED
4. INSULATE ALL RING TERMINALS WITH NEOPRENE SLEEVES

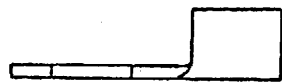
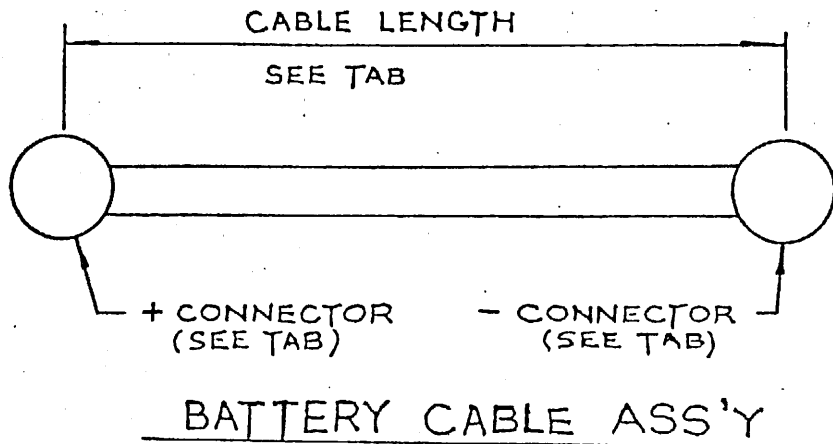

CONNECTOR 1G940-9,11

- 9 = (C)
- 11 = (D)

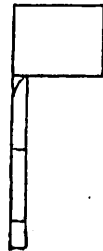

CONNECTOR 1G940-9,11

TANG BENT DOWN 90°

- 9 = E
- 11 = F

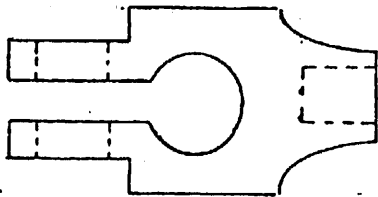

CONNECTOR 11087 - POS.

(A)

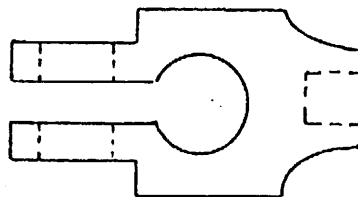

CONNECTOR 11086 - NEG

(B)

			-18				
-	-	1	-17	18"	D	E	
-	-	1	-16	37"	A	E	
-	-	1	-15	34"	B	D	
-	-	1	-14	50"	B	E	
1	-	-	-13	38"	D	C	32-R1
N/O	-	-	-12	13"	C	E	F&R-BR'
N/O	1	-	-11	7"	C	E	SP-1-GR'
3	2	1	-10	26"	C	E	R16-SP-1 ^{S1-B2} B2-B.
1	-	-	-9	42"	D	D	S1-K1
1	2	1	-8	10"	D	E	SP-1-K1
1	2	2	-7	26"	D	E	F&R-A1
2	4	3	-6	34"	D	E	F&R-S2 F&R-A2
1	1	1	-5	17"	B	C	B1--R16
1	1	-	-4	24"	B	E	B2--SP-1
2	2	1	-3	47"	A	E	B2+-SP-1 B1+-SP-1
1	-	-	-2	17"	A	B	BATTERY INTER CONCT
3	6	4	6062-1	12"	A	B	BATTERY INTER CONCT
C 36	TMP	SV 48	TAB NO	WIRE L.	POS CON. IDENT	NEG CON. IDENT	WIRE ROUTING

POWER CABLES

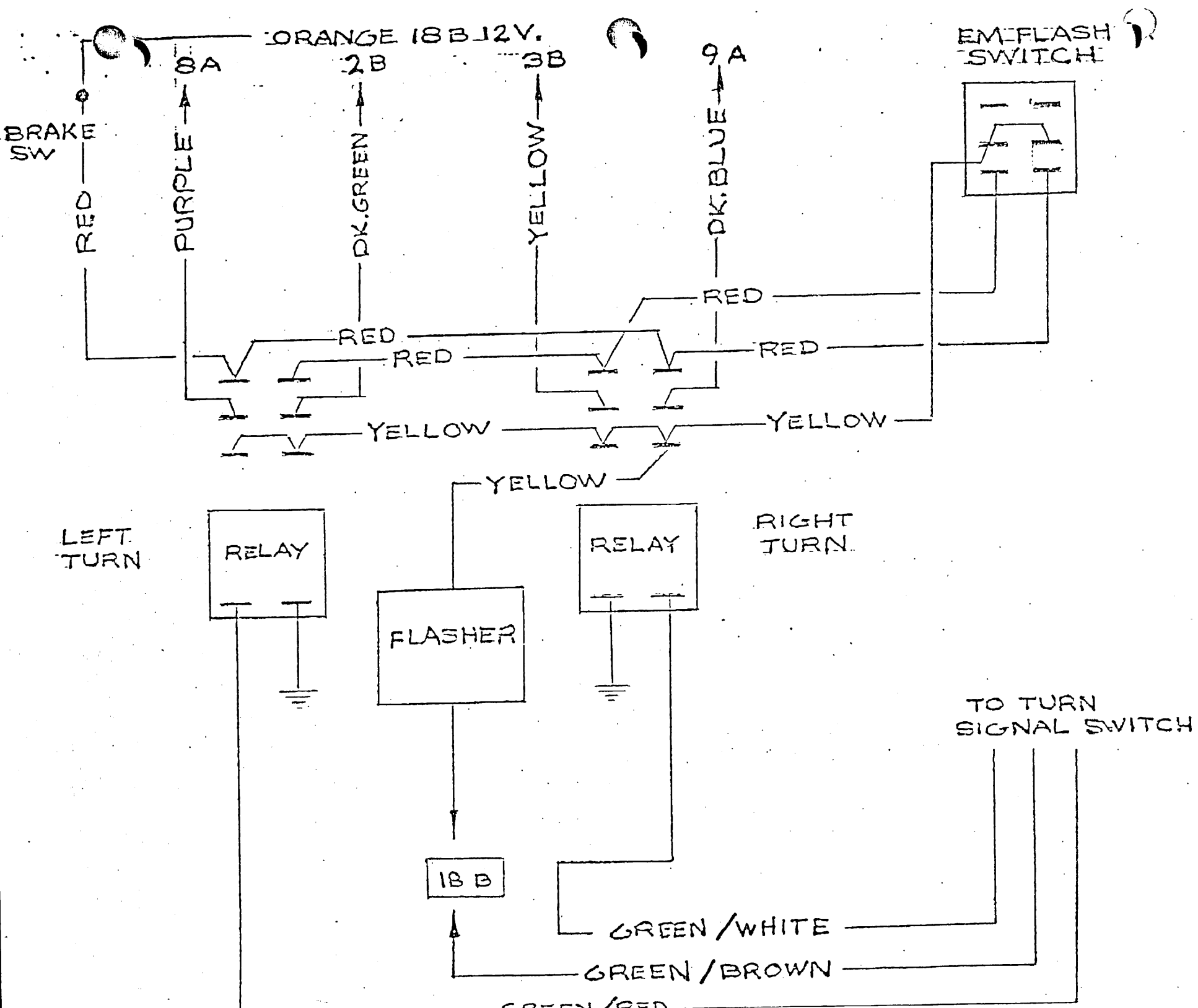

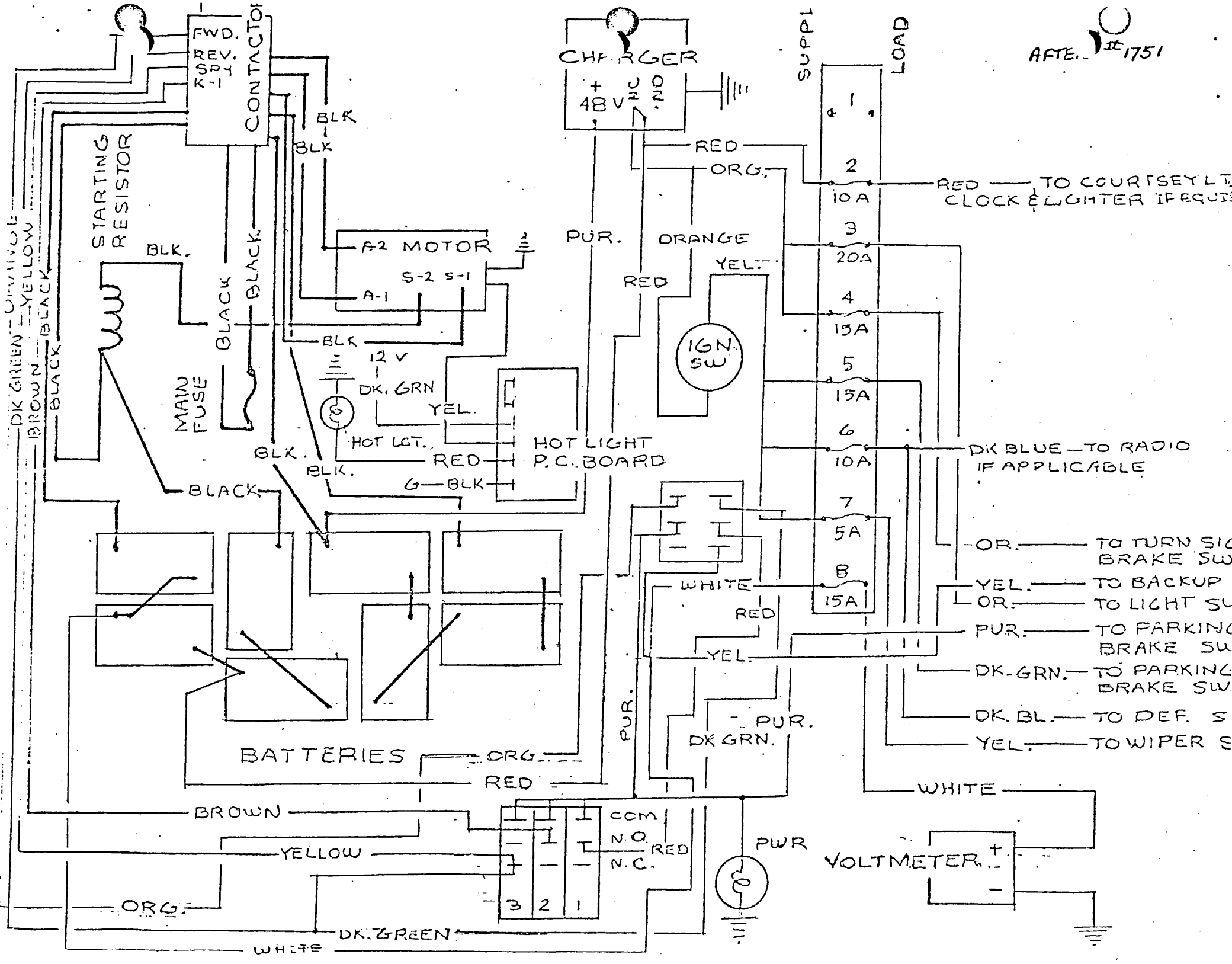

FROM FUSE NO. 4
 FROM FUSE NO. 5
 FROM FUSE NO. 3
 FROM SPEED SW.
 FROM FUSE NO. 5
 FROM FUSE NO. 6
 FROM FUSE NO. 7

YELLOW
 ORANGE
 PUR.
 DK. GREEN
 YEL.

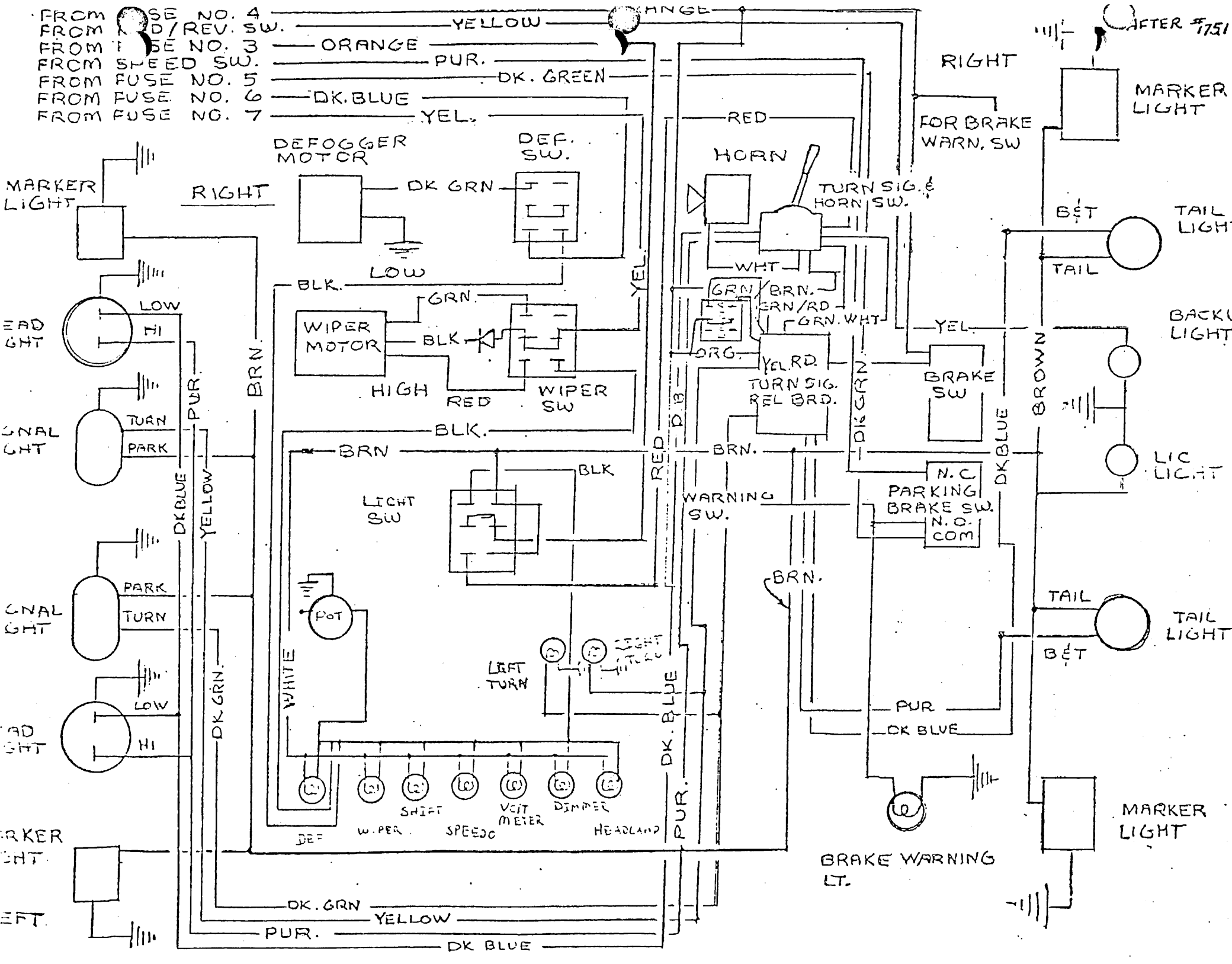

SV48 : 24SR1001-

SCHEMATIC, WIRING.
SV-48 1 of 2

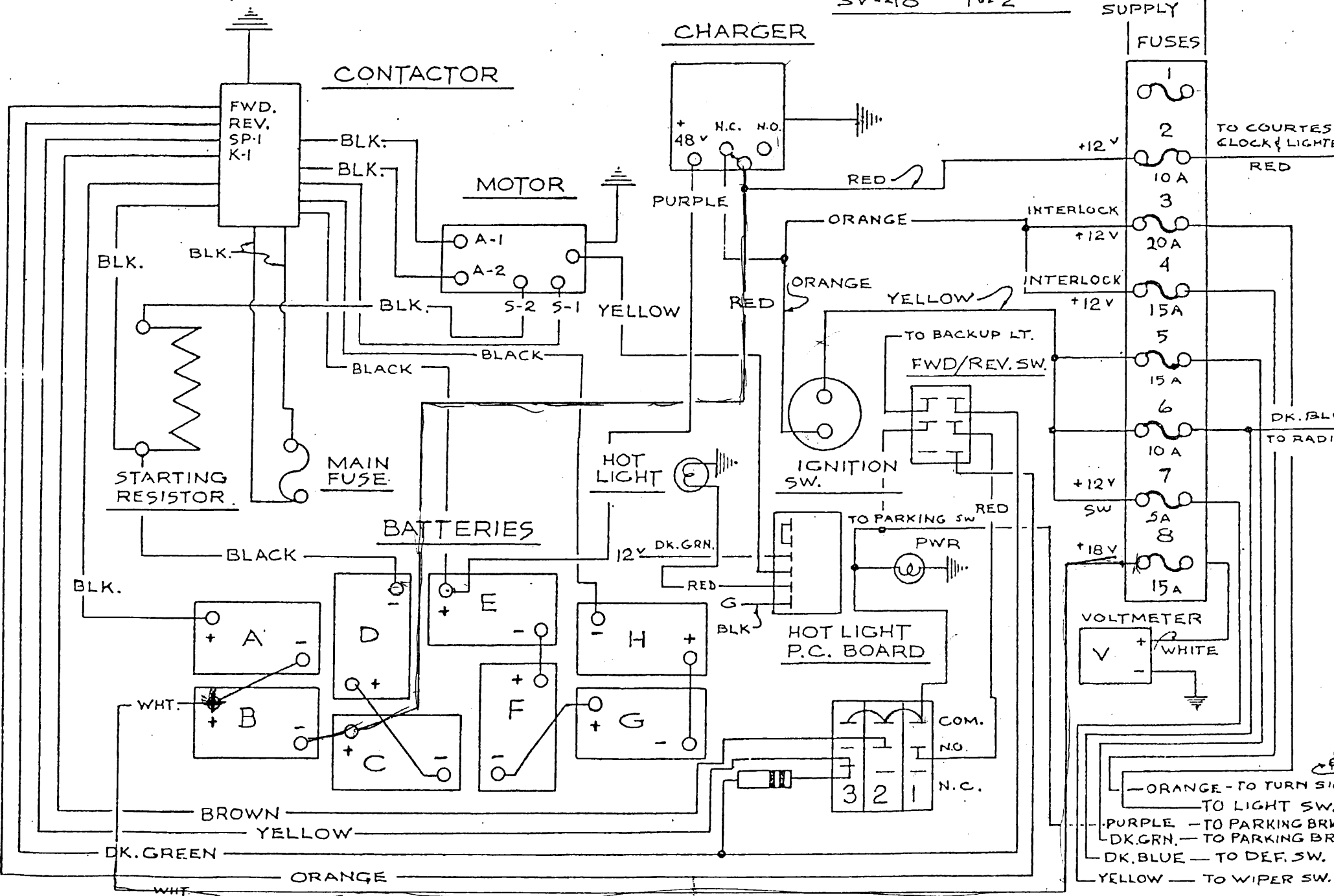

LOAD
SUPPLY
FUSES

1
2
3
4
5
6
7
8

10 A
20 A
15 A
15 A
10 A
5 A
15 A

TO COURTESY
CLOCK & LIGHTS
RED

INTERLOCK +12V
INTERLOCK +12V

TO BACKUP LT.
FWD/REV. SW.

TO PARKING SW
PWR

HOT LIGHT
P.C. BOARD

VOLT METER
V
WHITE

ORANGE - TO TURN SIG
TO LIGHT SW.
PURPLE - TO PARKING BRK
DK. GRN. - TO PARKING BR
DK. BLUE - TO DEF. SW.
YELLOW - TO WIPER SW.

FRONT OF CAR

★ DO NOT USE LONGER
SCREW INSULATION IS
TAPPED ONLY 5/8 DEEP

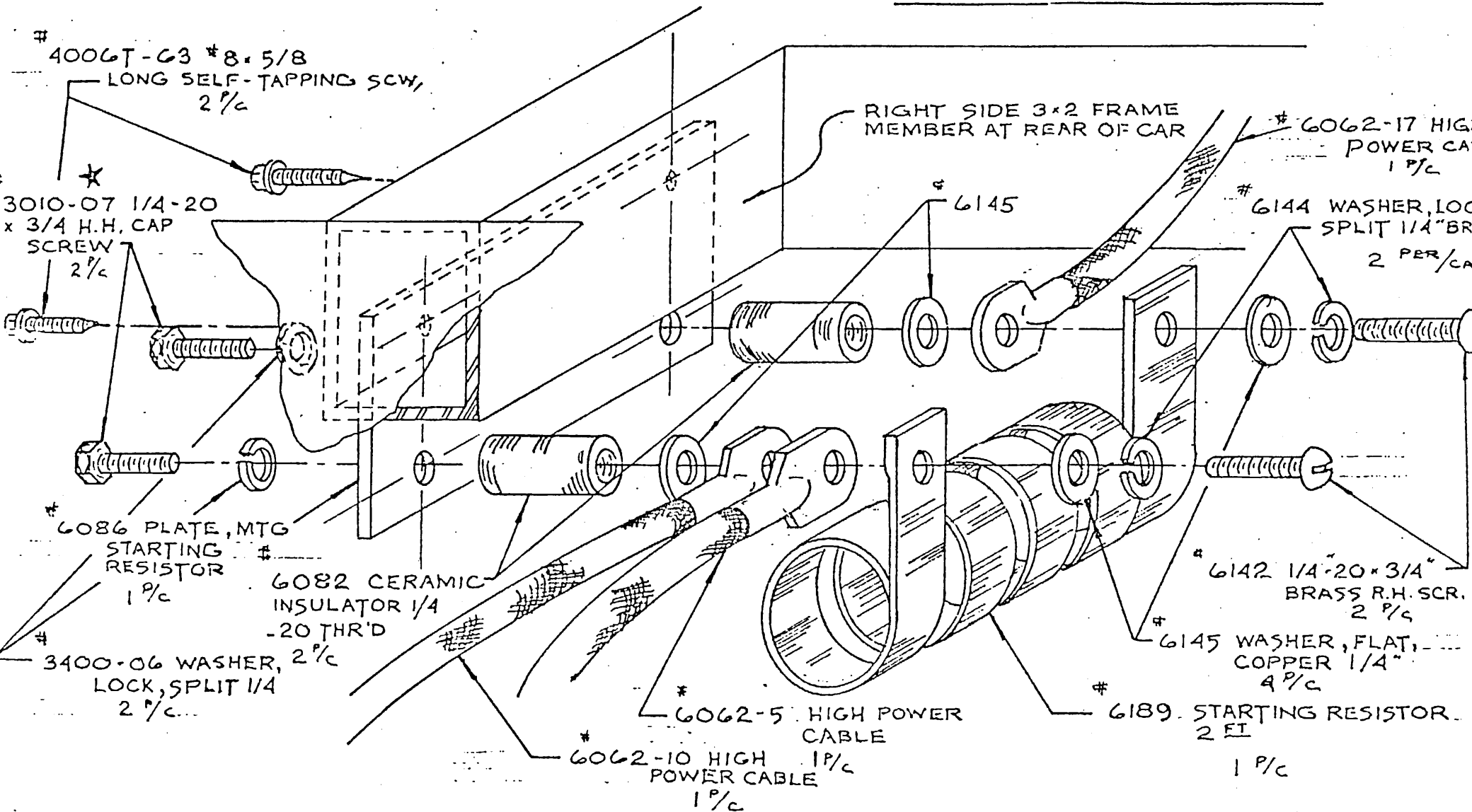

STARTING RESISTOR ASS'Y
SV-48

COMMUTER VEHICLES INC.
Subsidiary of General Engines Co., Inc.
Post Office Box 1479
Sebring, Florida 33870

Sebring Airport

Phone: (813) 655-2131

1. INSTALL BATTERIES 1 & 2 FIRST AS PER DIAGRAM

2. CONNECT PROPER LEADS:

REAR BATTERY BOX

ORANGE TO NEGATIVE

WHITE TO POSITIVE

SMALL WHITE WIRE 18 GAUGE IN REAR BOX WILL
HOOK ON TO NEGATIVE SIDE OF THE SAME BATTERY
THAT HAS NO. 2 WHITE WIRE

FRONT BATTERY BOX

PINK TO NEGATIVE

DOUBLE GREEN TO POSITIVE

3. INSTALL REMAINING BATTERIES AS PER DIAGRAM

4. INSTALL BUSS BARS IN CLOCKWISE DIRECTION

ALWAYS INSTALL FRONT BATTERIES FIRST

5. INSTALL BATTERY HOLD DOWN CLAMPS

PINK DOUBLE GREEN

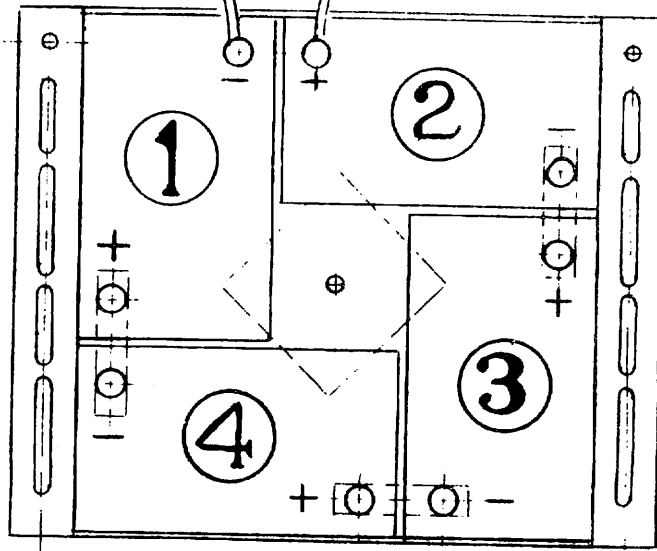

TO CENTER OF VEH. 

FRONT BATTERY LAY-OUT

ORANGE WHITE

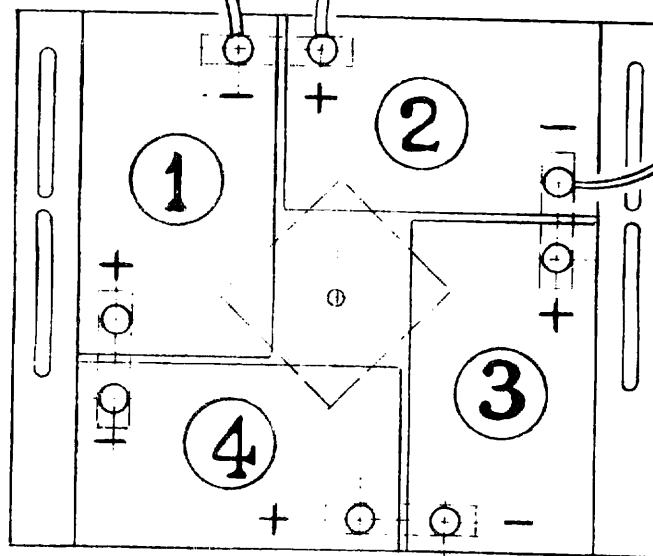

18 GA. WHITE
TO CENTER OF VEH. 

REAR BATTERY LAY-OUT

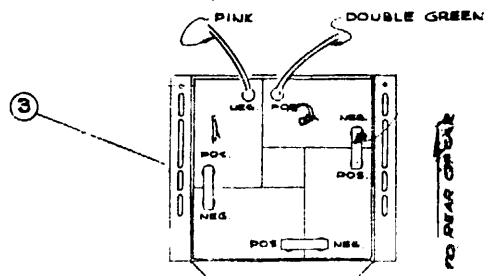

BATTERY LAY-OUT

ALIGN DIAGONAL HOLES ON SHOCK ABSORBER WITH CENTER LINE OF BUMPER.

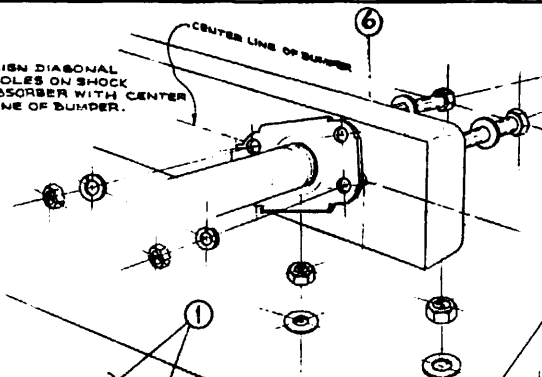

NOTE:
INSTALL SHOCK SUPPORT
MOUNT BEFORE PROCEDURE
USE (4) 3/8-16 H/H BOLT,
LOCKWASHER & NUT

ASSY PROCEDURE

1. INSERT ENERGY ABSORBERS INTO END CAPS MOUNTED ON FRAME (NOTE: USE THE 14 3/4 ABSORBERS IN REAR & 10 3/4 ABSORBERS IN FRONT)
2. SLIDE BATTERY BOX ONTO FRAME RAILS, ALIGN HOLES WITH HOLES IN FRAME. INSERT (4) 3/8-16 H/H BOLTS FROM BOTTOM WITH WASHER ON EACH IN, ADD SELF-LOCKING NUT **CAUTION: DO NOT OVER TORQUE (2-3 FT LBS)**
3. INSTALL BATTERIES IN BOX AS SHOWN IN DIAGRAM. INSTALL BUSS BARS ON REMAINING TERMINALS.
4. INSERT FRONT ENERGY ABSORBERS, FIRMLY SEATED IN CAPS, ADD REMAINING END CAPS.
5. INSTALL SHOCK ABSORBERS AS SHOWN USING 3/8-16-1" H/H BOLT, LOCKWASHER, & NUT (TYP. 8 PLACES)
6. INSTALL BUMPER AS SHOWN IN DIAGRAM, USING 3/8-16 H/H BOLT, LOCKWASHER & NUT NOTE: MOUNT BUMPER WITH PLUGS FACING DOWN

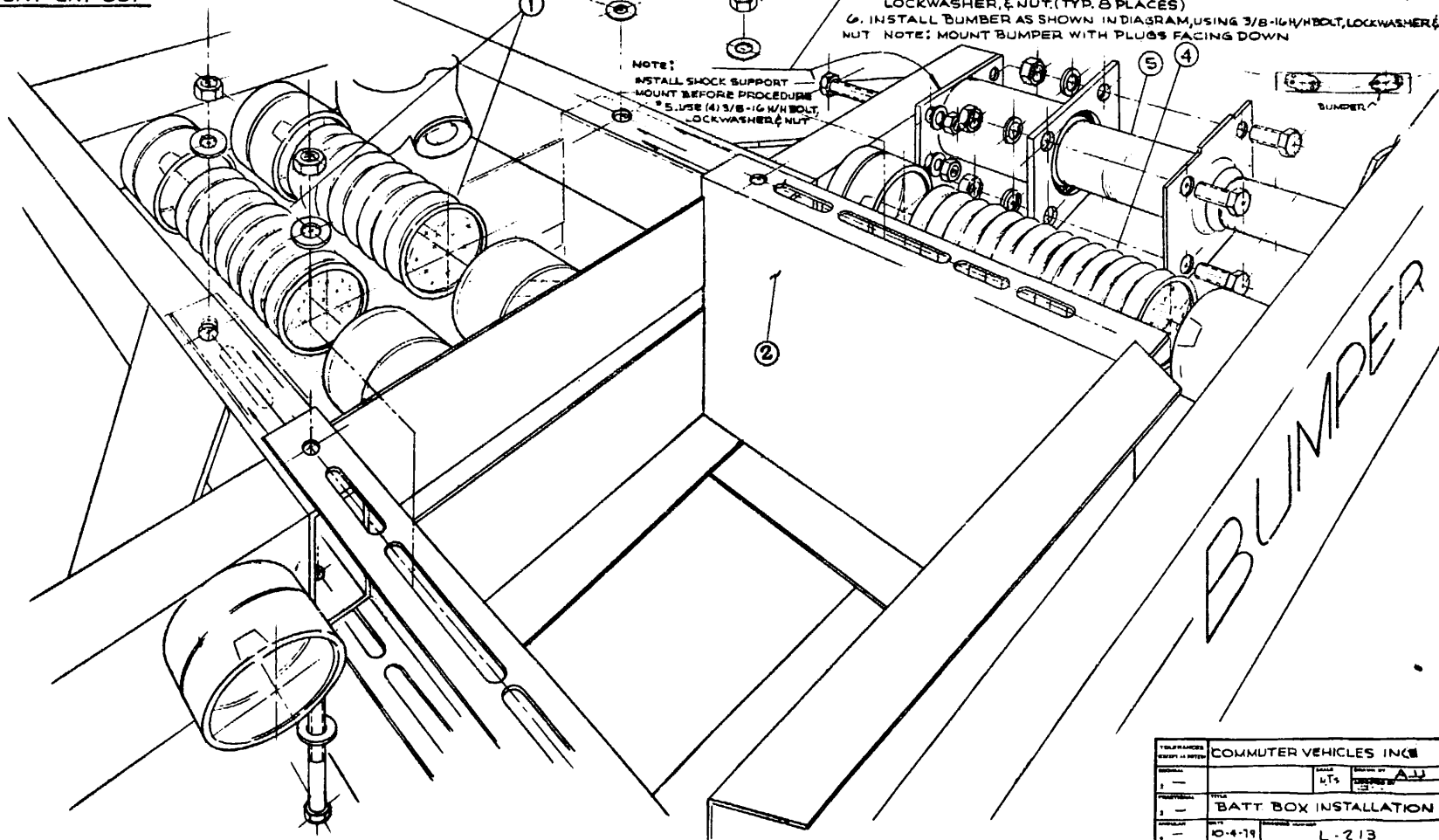

DESIGNED BY	COMMUTER VEHICLES INC.
DRAWN BY	UTS
CHECKED BY	AJJ
TITLE	BATT BOX INSTALLATION
DATE	10-4-79
REV.	L-213

OPERATIONAL PROCEDURES FOR VANGUARD AUTOMATIC CHARGER

Upon plugging charger into 110VAC 20 amp or better service, the internal interlock will cut in and charging will automatically begin.

A rate in excess of 30 amps is not uncommon for the first few minutes of operation into heavily discharged batteries.

The charge rate will average approximately 20 amps for the majority of the charge cycle and the amperage will gradually taper as the batteries approach full charge, but the voltage will increase.

When the majority of the cells have reached their full charge as determined by the total voltage of the battery, the charger will automatically shut down and the panel "ready" light will come on.

At this point the charger will begin pulsing the battery as required to maintain it in a full state of charge. As cell equalization improves during this time, the pulse rate will change with the "off" periods (light "on") increasing in relation to the "on" periods.

ONCE THE LIGHT STARTS TO FLASH, THE BATTERIES CAN BE CONSIDERED FULLY CHARGED FOR ALL PRACTICAL PURPOSES.

The charger can be left plugged in for long periods of time without heating the batteries, boiling off the electrolyte, or harming the batteries. It will automatically maintain the batteries in peak condition.

Economy and good judgment suggest that the charger should be unplugged when it is known that the vehicle is to remain idle for extended periods. Prior to placing the vehicle back in service, a short charge duration should again signal with the "ready" light that the batteries are in peak condition.

SPECIFICATIONS - [REDACTED] AUTOMATIC CHARGER

The automatic charger has been developed specifically for ~~[REDACTED]~~ ^{COMMUNAL} electric vehicles. It is of solid state design and is cut off controlled by the cell voltage of the batteries, as opposed to the timed charger.

Characteristically, a lead acid storage battery cell will exhibit a voltage rise from the 2.2 volts during charge, to over 2.45 volts as it reaches full charge. It is this voltage rise which controls the ~~[REDACTED]~~ charger, turning it completely off and lighting a "ready light" ~~[REDACTED]~~. Once this point is reached, the charger will continue to monitor the battery and send short timed pulses to the battery as required to keep it in full charge without destructive heating. The charger may be left on indefinitely without harming the battery. Electrolyte boil off is minimized, and cell equalization is excellent.

SPECIFICATIONS:

Input: 110VAC 60 CPS 15 Amps 20 Amp service required.

Output: 25-28 amp charge rate (start) into 24 cell battery system

Customer Controls: None

Charge Lamp ^{ON Dash} and Ready Lamp ~~[REDACTED]~~

Interlock: Provided internal to charger

Circuit Protection: External ^{Built in} 40 Amp circuit Breaker

Size: 12" wide 6.5" deep 6" high overall

Weight: 22 pounds (~~[REDACTED]~~)

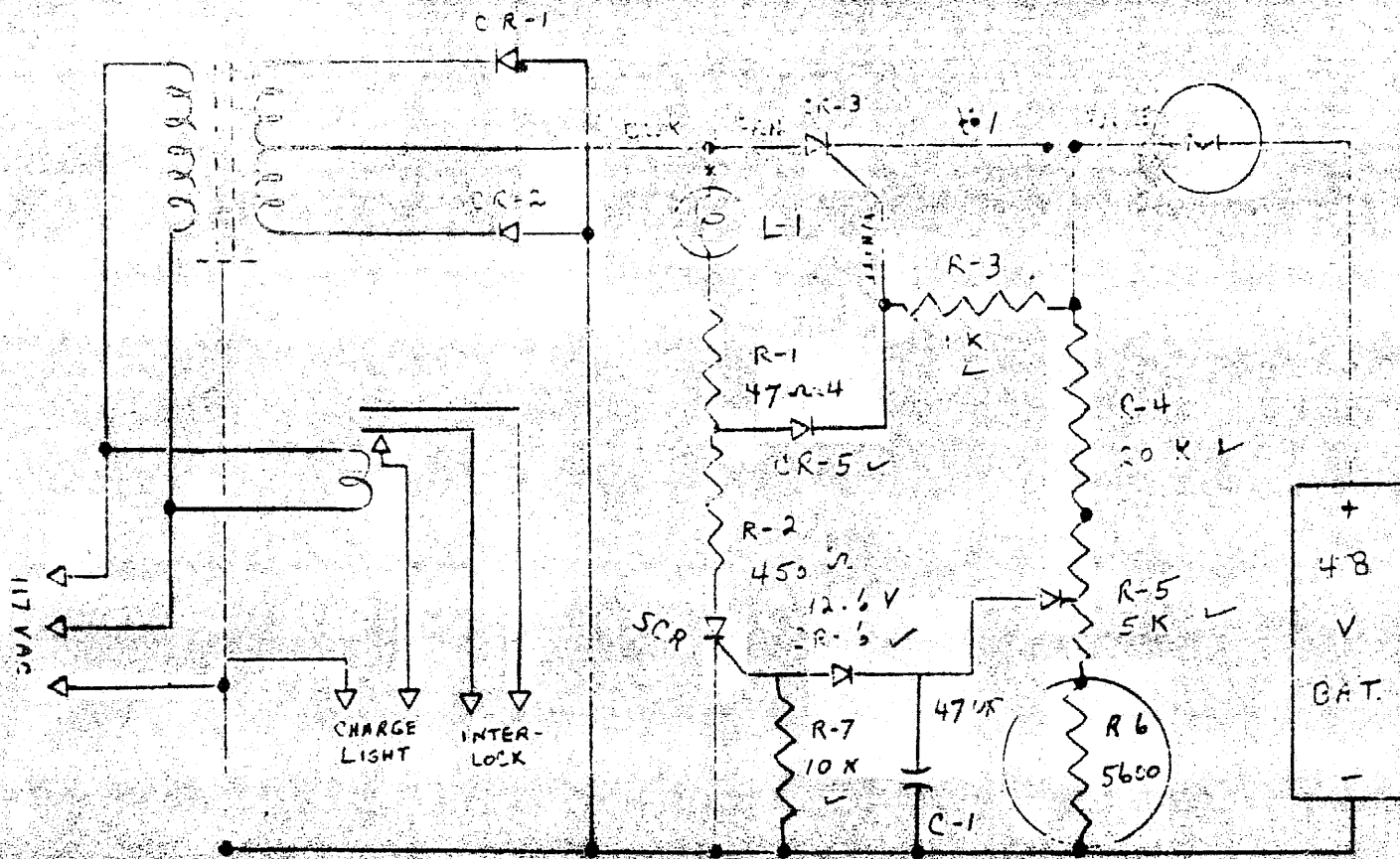

AUTOMATIC CHARGER CIRCUIT

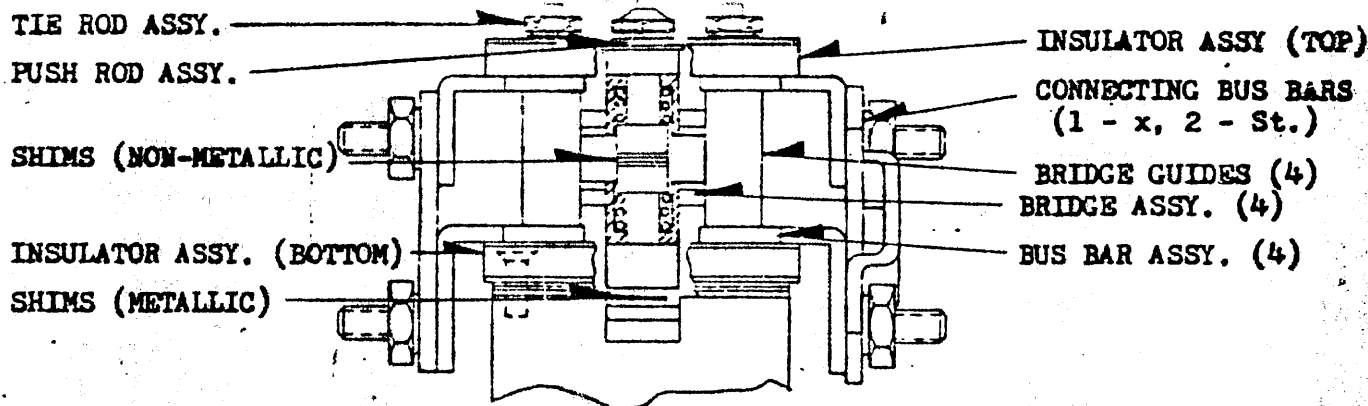

HB70BC (Forward and Reverse Contactor)

DO NOT DISTURB THE TOP SIDE FRAME SCREWS (CLOSEST TO THE CONTACT SECTION) SINCE THESE DETERMINE THE TOTAL CORE STROKE.

1. Remove nut, lockwasher, and flatwasher from each connecting bus bar (1 X and 2 Straight), and remove connecting bus bars.
2. Remove nut, lockwashers, and flatwashers from each tie rod assembly (4), remove the 1/32 inch insulation and the 1/4 inch insulator and bus bar assembly.
NOTE: Remove screws and bus bar assembly (4) from the 1/4 inch insulator and bus bar assembly, and assemble using new replacement bus bar assemblies in the identical orientation.
3. Remove bridge guides and tubing from the tie rod assemblies (if ceramic guides are cracked or chipped-replace).
NOTE: During assembly make sure the tubing is fully seated down into the bottom insulator and bus bar assembly.
Remove nut, lockwasher, and flatwasher from each pushrod assembly (2).
NOTE: During assembly use a standard nut to secure the bridge assembly while adjusting the contact gap. This minimizes the possibility of any relaxation of the flex lock nut due to repeated removal and tightening.
5. Remove top large shoulder bushing (base up), bridge assembly, spring main contact, top small shoulder bushing (base down), shims (washer - non-metallic), bottom small shoulder bushing (base up), bridge assembly, and spring - main contact, and bottom large shoulder bushing (base down) leaving all shims - washer/metallic - in place. (These shims control the bottom deck N. O. contact gap)
6. Remove screws and bus bar assemblies from bottom insulator and bus bar assemblies (4).
7. If the 1/32 inch insulation or the 1/4 inch insulator assembly are burned or severely discolored they should be replaced.
8. Assemble contactor in reverse of above (Steps 6 - 1).

CONTACTOR CHECK:

1. Torque requirements: 6-32 nuts/ 10 inch pounds;
8-32 nuts/ 20 inch pounds;
10-32 nuts/ 30 inch pounds.
2. There should be no binding or friction of the movable contact assembly when operated mechanically.
3. Contact normally open gaps should be .070 inch \pm 7%; Contact overtravel should be .050 inch \pm 7%. NOTE: Contact gaps can be checked using .070 inch feeler gage. Overtravel distance can be checked by closing and seating the contact on one deck, and measuring the N. O. contact gap on the opposite deck at .120 inch \pm 7%.
4. Coil pickup at room temperature: Intermittent duty - 50% of system rating;
Continuous duty - 65% of system rating.

Contact gap adjustment required in sequence: A. Bottom deck N. O. gap - increase shims (washer-metallic) to increase gap; decrease shims to decrease gap. B. Top deck N. O. gap - increase shims (washer/non-metallic) to decrease gap; decrease shims to increase gap. C. The correct contact overtravel is necessary in order to have the correct contact pressure for proper operation of the contactor.



Commuter Vehicles Inc.

December 22, 1980

TO: ALL COMUTA CAR DEALERS

SUBJECT: PAINT TOUCHUP

Due to the Dupont Imron paint that is used on the Comuta Car, we have been advised that touch up kits on that paint would not be available.

Please note the Dupont Imron Paint Numbers for our standard colors below:

COLOR	DUPONT IMRON PAINT NUMBER
Standard Blue	92095U
Yellow	54701U
Red	29198UM
Green	74844UH
Orange	5080UH
<u>White</u>	7372U
Custom Dark Blue	44426UH

Please contact Jerry Delaney on warranty program in reference to paint touch-ups on vehicles.

Barbara A. Woodley
Barbara A. Woodley
Sales Administration

BW/me

Technical Service Bulletin

SERVICE & PARTS DIVISION



DURING BRAKE PEDAL RETURN, THE MICRO SWITCH CONTROL ARM MAY BE BENT OUT OF POSITION CAUSING THE BRAKE LIGHTS TO STAY ON.

DATE 8/20/80

CORRECTION

REMOVE THE BRAKE PEDAL ASSEMBLY FROM THE CAR AND DISASSEMBLE THE MASTER CYLINDER PUSH ROD FROM THE PEDAL ARM. REMOVE THE $\frac{1}{4}$ INCH RETAINING NUT AND THE LARGE METAL WASHER FROM THE MASTER CYLINDER SHAFT. REINSTATE THE $\frac{1}{4}$ INCH RETAINING NUT FIRST, THEN PLACE THE WASHER ON THE SHAFT, AND REINSTALL THE ASSEMBLY WITH THE LARGE WASHER AGAINST THE FULCRUM OF THE BRAKE PEDAL.

REMOVE THE SWITCH ASSEMBLY LOCKING NUT. ALIGN THE SWITCH CONTROL ARM TO BE STRAIGHT. REMOVE THE ELECTRIC CONNECTOR FROM THE MICRO SWITCH AND MOVE THE CONNECTOR TO THE OTHER TERMINAL ON THE TOP OF THE SWITCH.

Subject

BRAKE LAMP SWITCH STAYS IN "ON" POSITION

REINSTALL CONFIGURATION OF SWITCH

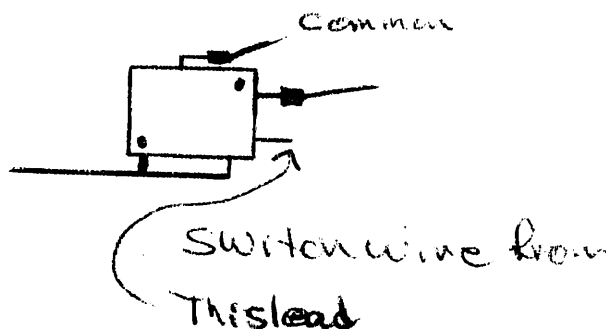

REINSTALL SWITCH ASSEMBLY IN REVERSE POSITION FROM ORIGINAL POSITION. REINSTALL LOCKING NUT AND REINSTALL BRAKE PEDAL ASSEMBLY.

VEHICLES COVERED

SN# 500 THRU #680

CHECK FOR PROPER OPERATION.

No. 80-102



Post Office Box 1479, Sebring Airport, Sebring, Florida 33870

Technical Service Bulletin

SERVICE & PARTS DIVISION



THE 300 AMP FUSE, CONNECTING THE TWO SPEED CONTACTORS, WILL FAIL PREMATURELY CAUSING CUSTOMER INCONVENIENCE AND SALES RESISTANCE. THIS IS CAUSED BY EXCESSIVE HEAT BUILD-UP IN THE FUSE AREA RESULTING IN PREMATURE FUSE FAILURE.

DATE 9-4-80

CORRECTION

1. REMOVE BATTERY CABLE IN EACH BATTERY PACK
2. REMOVE FUSE IN NORMAL MANNER
3. REMOVE TWO STEEL FUSE STANDOFFS
4. REMOVE PLASTIC CONTACTOR COVER
5. REPLACE NEW FUSE AGAINST CONTACTOR STUDS
6. WITH SMALL HAND SAW OR OTHER CUTTING TOOL, REMOVE AREA AROUND STANDOFF HOLES IN CONTACTOR COVER. SEE ATTACHED TEMPLATE
7. REPLACE CONTACTOR COVER
8. RECONNECT BATTERY CABLES

Subject
300 AMP FUSE
FAILURE

VEHICLES COVERED
ALL VEHICLES

STANDARD TIME ALLOWANCE FOR THIS OPERATION IS .3 HR.

No. 104



**Commuter
Vehicles Inc.**

Post Office Box 1479, Sebring Airport, Sebring, Florida 33871

Technical Service Bulletin

SERVICE & PARTS DIVISION



DATE 9-4-80

Subject

300 AMP FUSE
FAILURE
CUTTING TEMPLATE

VEHICLES COVERED
ALL VEHICLES

No. 104A

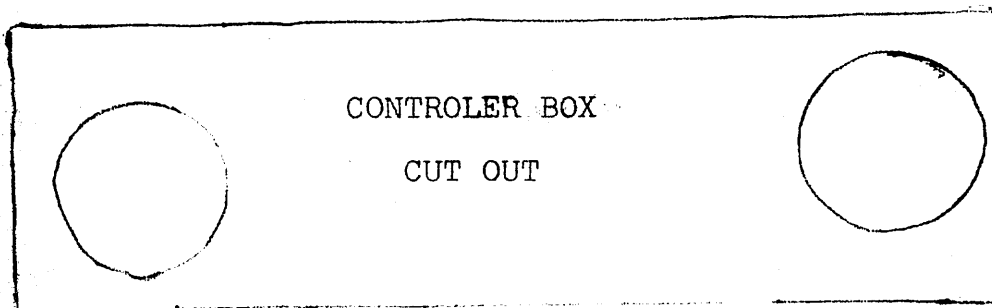

CUT ON THIS LINE

STAND OFF HOLES



**Commuter
Vehicles Inc.**

Post Office Box 1479, Sebring Airport, Sebring, Florida 33870

Technical Service Bulletin

SERVICE & PARTS DIVISION



DATE 9-4-80

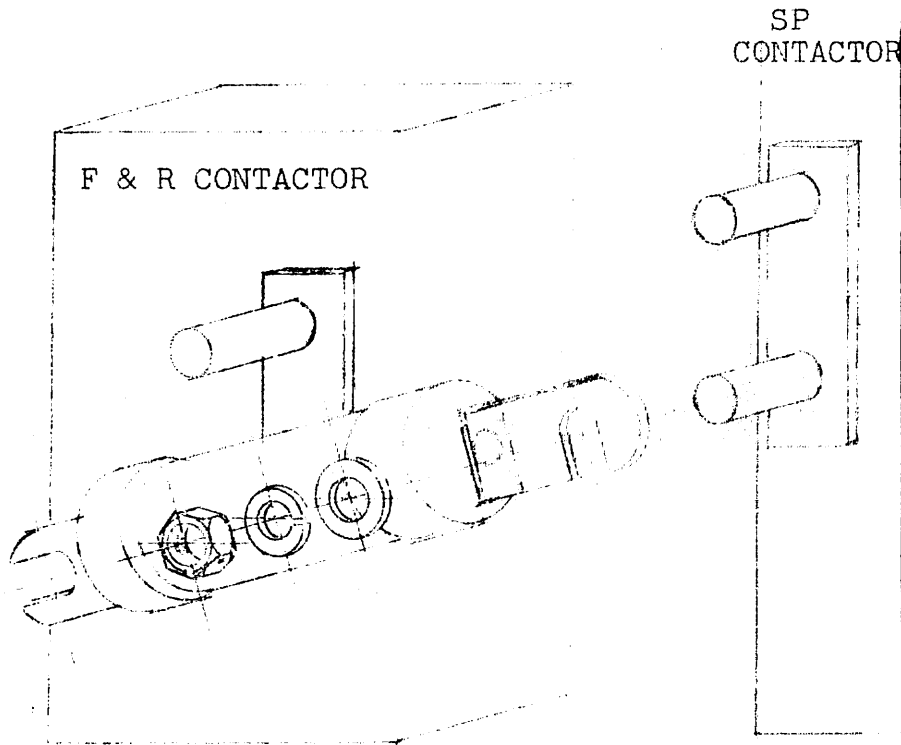

Subject

300 AMP FUSE
FAILURE

VEHICLES COVERED

ALL VEHICLES

No. 104B



**Commuter
Vehicles Inc.**

Post Office Box 1479, Sebring Airport, Sebring, Florida 338

- Q. How fast does the Comuta-Car by Commuter Vehicles, Inc. go?**
A. The current version, Comuta-Car CV-48 cruises at up to **38** miles per hour.
- Q. Can the Comuta-Car be licensed for on-the-road use?**
A. The Comuta-Car complies with all Federal Motor Vehicle Standards applicable to that vehicle. Therefore, it should be licensable in all states.
- Q. What is the Comuta-Car designed for?**
A. The Comuta-Car is designed for low speed, short distance driving by housewives, commuters, students, retired persons, etc., the Comuta-Car is also ideal for such off-road uses as security patrol, in-plant transportation, etc. The Comuta-Car has been sold as a messenger and delivery vehicle and is useful for city meter maids and utility companies.
- Q. How far will the Comuta-Car go before recharging?**
A. The range is up to 50 miles, depending on temperature, terrain, and traffic conditions. Thirty-five to forty miles is a typical range in city driving conditions. Fortunately, the Comuta-Car does not use energy when stopped at a light or coasting to a stop.
- Q. Will the Comuta-Car fulfill my driving needs?**
A. Chances are it will. The average urban and suburban automobile in the United States is driven only 22.6 miles per day. This makes the Comuta-Car a very practical second or third car for many families.
- Q. How does the top speed hold up as the Comuta-Car is driven during the day?**
A. A top speed of 35-38 miles per hour should be attainable during all but the last few miles of the charge.
- Q. How will the Comuta-Car handle in snow?**
A. Exceptionally well; its low center of gravity plus the rear-mounted motor and transaxle provide excellent traction.
- Q. What effect do the lights and wiper have on the range of the Comuta-Car?**
A. The lights and wipers do not effect the vehicle's range due to its completely isolated 12 volt control circuit.
- Q. Can the Comuta-Car be towed?**
A. Only for short distances at low speed. We recommend using a trailer when taking the Comuta-Car on vacation.
- Q. How will the Comuta-Car handle on hills?**
A. Very well. The Comuta-Car performs on most hills at 25-28 mph. Coming down steep hills you can coast and conserve power achieving speeds up to 40 mph.
- Q. Is the Comuta-Car really pollution free?**
A. Electric vehicles are classified as inherently non-polluting vehicles by the U.S. Environmental Protection Agency. The relatively little pollution that is emitted from the power plant is usually far from populated areas and is easier to control than automobile pollution. Of course, many power plants do not burn fossil fuels, and in these cases the Comuta-Car is virtually pollution-free.
- Q. Do electric vehicles indirectly burn just as much fuel as conventional cars via the electric power plant?**
A. No, because fuel-burning power plants which generate electricity for the Comuta-Car can operate more efficiently than small internal combustion engines, the Comuta-Car actual fuel usage is only a fraction of that of an average sub-compact.
- Q. If millions of electric vehicles were used around the country, wouldn't this cause black outs and brown outs?**
A. Surprisingly enough, no. Electric vehicles would most likely be recharged at night during off peak periods, when utility companies have sufficient capacity to recharge many millions of electric vehicles. In this way, power plants will operate more efficiently and electricity rates may stabilize.
- Q. Could the Comuta-Car be powered by solar energy?**
A. Yes, the vehicle's charging system can be supplemented by the use of solar panels.

- Q. Can electric vehicles be made to go faster and further?**
A. Yes, but at a much greater cost. We have designed the Comuta-Car based on a comprehensive survey that urban traffic moves at an average of 28 miles per hour, and that most "second cars" are driven only 5-40 miles per day.
- Q. Is the Comuta-Car as safe as the average small car?**
A. The Comuta-Car is equipped with seat and shoulder belts and other safety equipment required by law. It is constructed on a rugged aluminum chassis and has a tubular aluminum body support structure surrounding the passenger compartment. Because the Comuta-Car will not be used on interstate highways, the possibility of a high speed collision is eliminated. We feel that these features and the fact that the Comuta-Car will be used only in low speed areas make it one of the safest small cars on the road today.
- Q. What about insurance?**
A. Insurance should be no different from any other compact motor vehicle. In fact, because the Comuta-Car will be used only at low speeds and for short-distance driving around town, we think rates for this vehicle will someday be less than for cars driven at highway speeds and for possible hundreds of miles per day.
- Q. What makes the Comuta-Car a good investment?**
A. The Comuta-Car is a good investment because of its low operating costs, low maintenance costs, and anticipated low depreciation.
- Q. Will the Comuta-Car depreciate as fast or as much as a conventional car does?**
A. We think not. The Comuta-Car frame is constructed of corrosion-resistant aluminum. The body is of rust-proof cycloc ABS, a high quality aircraft type finish. Also there is no internal combustion engine with its associated support systems to require repair or replacement. For these reasons, the Comuta-Car should retain more of its value over a longer period than a conventional car.
- Q. How much maintenance does the Comuta-Car require?**
A. Much less than for a conventional car. The Comuta-Car has no spark plugs, points, mufflers, radiator, valves, rings, carburetor, anti-pollution controls, or transmission. The batteries are the most important part of the Comuta-Car and should be checked weekly. (Consult your owner's manual for correct procedures.)
- Q. How much battery maintenance does the Comuta-Car require?**
A. Approximately 15 minutes per week to refill the batteries with distilled water.
- Q. How long will the batteries last?**
A. With proper care in accordance with the owner's manual, the batteries should last from 12,000 to 18,000 miles, under normal use.
- Q. How much does replacing batteries add to the cost of operating Comuta-Car?**
A. On the average about 2 to 3 cents per mile.
- Q. How do the Comuta-Car batteries differ from regular car batteries?**
A. These heavy-duty 6-volt batteries are designed for hundreds of recharging cycles, which electric vehicles require.
- Q. How will I know when my batteries need recharging?**
A. The Comuta-Car voltmeter will indicate approximately when a recharge is necessary.
- Q. How do I recharge the batteries?**
A. The Comuta-Car is equipped with a built-in on-board charger. The batteries may be recharged by simply plugging the charger cord into any standard 110 volt household outlet.
- Q. How long does it take to recharge the batteries?**
A. Usually overnight, depending on the state of battery discharge, in turn, depending on daily mileage.
- Q. How does the cold weather affect the Comuta-Car?**
A. The efficiency of the batteries decreases proportionately to the temperature drop. If the batteries are kept in a state of charge during non-use, loss of battery efficiency can be minimized.

- Q. How much does an average battery recharge cost?**
A. About 25 cents, depending on local rates. The Comuta-Car CV-48 will go about three city miles on one KWH of electricity. Consult your local utility company to compute the per mile cost of operating a Comuta-Car in your area. Also, ask if your utility company sells off-peak electricity at a cheaper rate.
- Q. Why not attach a generator or alternator to the Comuta-Car in such a way that the batteries can be recharged during operation?**
A. This had not been shown to be an effective way of increasing range because more energy is required to turn the generator than is won.
- Q. Is there a chance that my Comuta-Car could run out of charge while on the road?**
A. Not very much, unless you have forgotten to recharge the Comuta-Car the night before. However, if the Comuta-Car does run out of charge before you return home, (perhaps you had to run an unexpected errand at the end of the day), by simply resting for 15 or 20 minutes, the batteries should recharge themselves enough to get you a mile or so further.
- Q. Is air-conditioning available?**
A. No, this would cause too much of a drain on the batteries. However, because the Comuta-Car has large side windows and because there is no engine heat to leak into the passenger compartment, air-conditioning should not be needed.
- Q. Suppose I drive my Comuta-Car for 20 or 30 miles in the morning; can I charge up the batteries for an hour or so during lunch before going out again in the afternoon?**
A. Yes, indeed. Every little bit helps. Some customers report driving as far as 70 miles a day by recharging the batteries whenever the Comuta-Car is not in use.
- Q. I have to drive thirty miles to work every morning. Could the Comuta-Car meet my commuting needs?**
A. If your employer will find you a place to charge up the Comuta-Car during the day, you should have enough charge for the return trip in the evening.
- Q. Why should I buy a Comuta-Car instead of a small similarly priced sub-compact?**
A. In addition to the fact that the Comuta-Car is a good investment an electric vehicle is inherently pollution-free and it can be operated independent of the available supplies of gasoline. Energy independence is one of our country's greatest goals and everyone must do his part to help.
- Q. Who can service my Comuta-Car?**
A. Any authorized Commuter Vehicles, Inc. dealer. The Comuta-Car is designed so simply that many owners will find that they can perform most service tasks themselves. Technical assistance is always available through the Customer Service department of Commuter Vehicles, Inc.
- Q. Are replacement parts available?**
A. Yes, at any authorized Commuter Vehicles, Inc. dealer, or at the Commuter Vehicles, Inc. National Service Department, Sebring Fla. 33870.
- Q. What about the motor?**
A. The electric motor is a heavy-duty 6 HP series wound G.E. motor designed to last for many years. Very little maintenance is required.
- Q. Where can I buy a Comuta-Car?**
A. At any authorized Commuter Vehicles, Inc. Sales and Service dealership. Contact the National Sales Office of Commuter Vehicles, Inc. for the name of the dealer nearest you.

comuta-car

tomorrow's transportation here today!

SPECIFICATIONS*

LENGTH — 117" **FRONT TRACK** — 43"
WIDTH — 55" **REAR TRACK** — 44"
WHEELBASE — 63" **CLEARANCE** — 5½"
HEIGHT — 60" **WEIGHT** — 1475 lbs.

REAR STORAGE — 12 Cubic Feet

TIRES — 135 X 13, Radial

SPEED — 40 mph cruising

RANGE — Up to 40 miles

ACCELERATION — 0 to 25 — 6.2 seconds
0 to 35 — 19 seconds

TURNING — 30 Feet

CONTROLLER — Multivoltage speed control.

MOTOR — Series wound DC 6 HP.

DIFFERENTIAL — Direct pinion drive.

SUSPENSION — Leaf springs, front and rear.
4 wheel shock absorbers.

BODY — Impact resistant Cycloc (ABS) rust
and corrosion proof.

FRAME — Rectangular aluminum chasis, tubular
aluminum body support.

BRAKES — Four wheel hydraulic brakes, parking
brake.

POWER SOURCE — Eight 6 volt batteries (HD)

**Specifications, equipment and available colors are subject to change without notice.*

STANDARD EQUIPMENT: 110 volt on board built in charger - high impact energy absorbing bumper system - laminated safety glass windshield - shoulder harness and seat belt assembly - head rest - dual speed windshield wiper - windshield washer - wheel covers - vinyl top - custom wood grain trimmed interior - rear parcel area carpeting - 25' Heavy Duty extension cord - radial tires - defroster.

BODY COLORS: Artic White, Bermuda Blue, Cascade Red, Mandarin Orange, Sebring Green, Sun Country Yellow; Special Extra Cost — Bar Harbor Blue (Metallic)

OPTIONS: Radio AM & FM; Radio AM/FM 2 speakers; Radio AM or FM 8 track or cassette 2 speakers; Tinted windshield; Spare tire & Comuta-Car jack; Right-side view mirror; Cigar lighter, Comuta-Car trailer (standard); Comuta-Car trailer (deluxe, colored-keyed to car); White-wall tires; White wheels; Custom full wheel covers; Body side moldings (not available on custom sport model); Front protective floor mats; Dash mounted digital clock; Hatchback rear window; Side decor rally stripes; Custom sport option includes side decor rally stripes, full wheel covers, hatchback rear window, sport option decals, sport grip steering wheel cover.

LIMITED WARRANTY: Under normal use, the Comuta-Car is warranted by Commuter Vehicles, Inc. for a period of six months after purchase by the customer. This warranty applies to all parts of the vehicle found defective in material or workmanship; except for tires and batteries, which are warranted separately by their respective manufacturers.

This is a summary of the entire warranty, which is available at your authorized Commuter Vehicles, Inc. dealership.



Specifications

&

Answers

to

Questions

Farrell Pelfrey
979-6390
393-3654

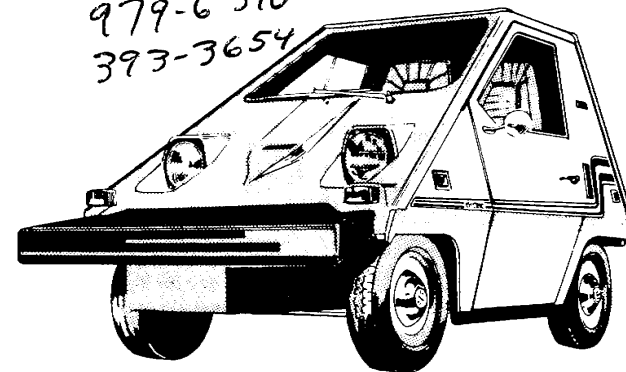

ELECTRIC



- Q. How fast does the Comuta-Car go?**
A. *The current model Comuta-Car 111DW cruises at up to 40 miles per hour.*
- Q. Can the Comuta-Car be licensed for on-the-road use?**
A. *The Comuta-Car complies with all current federal motor vehicle standards applicable to the vehicle. Therefore, the Comuta-Car should be licensed as you would any standard vehicle.*
- Q. What is the Comuta-Car designed for?**
A. *The Comuta-Car is designed with the second or third family vehicle in mind, for the frequent short distance driving by housewives, commuters, students, retired persons, etc. The Comuta-Car is also ideal for such off-road uses as security patrol, in-plant transportation, etc. The Comuta-Car has been sold as a messenger and delivery vehicle and is useful for city meter maids and utility companies.*
- Q. How far will the Comuta-Car go before recharging?**
A. *The range is up to 40 miles, depending on temperature, terrain and traffic conditions, once your vehicle has passed the initial break-in period with approximately 300 to 400 miles. Fortunately, the Comuta-Car does not use energy when stopped at a light or coasting to a stop.*
- Q. Will the Comuta-Car fulfill my driving needs?**
A. *Chances are it will provide 70% to 75% of your transportation needs. The average urban and suburban automobile in the United States is driven only 22.6 miles per day.*
- Q. How does the top speed hold up as the Comuta-Car is driven during the day?**
A. *A top speed of 40 to 43 miles per hour should be attainable during all but the last few miles of the charge.*
- Q. How does the Comuta-Car handle in snow?**
A. *Exceptionally well. Its low center of gravity plus the rear-mounted motor and transaxle provide excellent traction.*
- Q. How does the cold weather affect the Comuta-Car?**
A. *The efficiency of the batteries decreases proportionately to the temperature drop. If the batteries are kept in a state of charge during non-use, loss of battery efficiency can be minimized.*
- Q. What effect do the lights and wiper have on the range of the Comuta-Car.**
A. *The lights and wipers do not effect the vehicle's range due to its completely isolated 12 volt control circuit.*
- Q. Can the Comuta-Car be towed?**
A. *Only for short distances at low speed. We recommend using a trailer when taking the Comuta-Car on vacation.*
- Q. How will the Comuta-Car handle the hills?**
A. *Very well. The Comuta-Car performs on most hills 25 to 28 miles per hour. Coming down steep hills you can coast and conserve power achieving speeds up to 45 or 50 mph.*
- Q. Is the Comuta-Car really pollution free?**
A. *Electric vehicles are classified as inherently non-polluting vehicles by the U.S. Environmental Protection Agency. The relatively little pollution that is emitted from the power plant is usually far from populated areas and is easier to control than automobile pollution. Of course, many power plants do not burn fossil fuels, and in these cases the Comuta-Car is virtually pollution-free.*
- Q. How much battery maintenance does the Comuta-Car require?**
A. *Approximately 15 minutes per week to refill the batteries with distilled water.*
- Q. How long will the batteries last?**
A. *With proper care in accordance with the Owner's Manual, the batteries should last from 12,000 to 18,000 miles, under normal conditions.*
- Q. How much does replacing batteries add to the cost of operating the Comuta-Car?**
A. *On the average two to three cents per mile.*
- Q. How do the Comuta-Car batteries differ from regular car batteries?**
A. *These heavy-duty six volt batteries are designed for hundreds of recharging cycles, which electric vehicles require.*
- Q. How do I recharge the batteries?**
A. *The Comuta-Car is equipped with a built-in on-board charger. The batteries may be recharged by simply plugging the charger cord into any standard 110 volt household outlet.*
- Q. How long does it take to recharge the batteries?**
A. *Usually overnight, depending on the state of battery discharge.*
- Q. How much does an average battery recharge cost?**
A. *About 35 to 40 cents depending on local rate. The Comuta-Car model 111DW will go about three city miles on one KWH of electricity. Consult your local utility company to compute the per mile cost of operating a Comuta-Car in your area. Also, ask if your utility company sells off-peak electricity at a cheaper rate.*
- Q. Why not attach a generator or alternator to the Comuta-Car in such a way that the batteries can be recharged during operation?**
A. *This has not shown to be an effective way of increasing range because more energy is required to turn the generator than is won.*
- Q. Is there a chance that any Comuta-Car could run out of charge while on the road?**
A. *Yes, by not recharging overnight or watching the voltmeter you could possibly run out of charge. However, the advantage over the combustion automobile is by simply resting for 15 or 20 minutes, the batteries should recharge themselves enough to get you a mile or so further.*
- Q. Is air-conditioning available?**
A. *No. This would cause too much of a drain on the batteries. However, because the design of the Comuta-Car's side windows and because there is no engine heat to leak into the passenger compartment, air conditioning should not be needed for those short commuting trips.*
- Q. Suppose I drive my Comuta-Car for 20 or 30 miles in the morning; can I recharge up the batteries for an hour or so during lunch before going out again in the afternoon?**
A. *Yes indeed. Every little bit helps. Some customers report driving as far as 70 miles or more per day by recharging the batteries periodically during the day time hours. Whenever the car is not in use.*
- Q. I have to drive 25 miles to work every morning. Could the Comuta-Car meet my commuting needs?**
A. *If your employer will find a place to charge up the Comuta-Car during the day, you should have enough charge for the return trip in the evening.*
- Q. Do electric vehicles indirectly burn just as much fuel as conventional via the electric power plant?**
A. *No. Because fuel-burning power plants which generate electricity for the Comuta-Car can operate more efficiently than small internal combustion engines, the Comuta-Car actual fuel usage is only a fraction of that of an average sub-compact.*
- Q. If millions of electric vehicles were used around the country, wouldn't this cause black outs and brown outs?**
A. *Surprisingly enough, no. Electric vehicles would most likely be recharged at night during off peak periods, when utility companies have sufficient capacity to recharge many millions of electric vehicles. In this way, power plants will operate more efficiently and electricity rates may stabilize.*
- Q. Can electric vehicles be made to go faster and further?**
A. *Yes, but at a much greater cost. We have designed the Comuta-Car based on a comprehensive survey that urban traffic moves at an average of 28 miles per hour, and that most "second cars" are driven only 5 to 40 miles per day.*
- Q. Is the Comuta-Car as safe as the average small car?**
A. *The Comuta-Car is equipped with seat and shoulder belts and other safety equipment required by law. It is constructed on a rugged aluminum chassis and has a aluminum body support structure surrounding the passenger compartment. Because the Comuta-Car will not be used on interstate highways, the possibility of a high speed collision is eliminated. We feel that these features and the fact that the Comuta-Car will be used only in low speed areas makes it one of the safest small cars on the road today.*
- Q. What about insurance?**
A. *Insurance should be no different from any other compact motor vehicle. In fact, because the Comuta-Car will be used only at low speeds and for short-distance driving around town, in some areas rates have been lowered.*
- Q. What makes the Comuta-Car a good investment?**
A. *The Comuta-Car provides economical operating cost, low maintenance costs and low depreciation value, making it a very good investment.*
- Q. Will the Comuta-Car depreciate as fast or as much as a conventional car does?**
A. *No. The Comuta-Car frame is constructed of corrosion resistant plastic. The body is of rust-proof cycloc ABS, a high quality aircraft type finish. Also there is no internal combustion engine with its associated support system to require repair or replacement. The light weight of the Comuta-Car gives the tires longer life. For these reasons, the Comuta-Car should retain more of its value over a longer period than a conventional car.*
- Q. How much maintenance does the Comuta-Car require?**
A. *Much less than for a conventional car. The Comuta-Car has no spark plugs, points, mufflers, radiator, valves, rings, carburetor, anti-pollution controls or transmission. The batteries are the most important part of the Comuta-Car and should be checked weekly.*
- Q. Why should I buy a Comuta-Car instead of a small similarly priced sub-compact?**
A. *In addition to the fact that the Comuta-Car is a good investment, an electric vehicle is inherently pollution-free and it can be operated independent of the available supplies of gasoline. Maintenance on the Comuta-Car, under normal conditions can be performed by the owner, eliminating the high cost of servicing through mechanics, auto repair shops, etc.*
- Q. If repairs I cannot handle are required, who can service my Comuta-Car?**
A. *Any authorized Commuter Vehicles, Inc. dealer. Technical assistance is always available through our factory trained service representatives at all authorized Comuta-Car dealers.*
- Q. Are replacement parts available?**
A. *Yes, at any authorized Commuter Vehicles, Inc. dealer, or at the Commuter Vehicles, Inc. Customer Service Department, Sebring, Florida.*
- Q. What about the motor?**
A. *The electric motor is a heavy-duty 6 HP series wound G.E. motor, designed to last for many years. Very little maintenance is required.*
- Q. Where can I buy a Comuta-Car?**
A. *At any authorized Commuter Vehicles, Inc. dealer. Contact the National Sales Office of Commuter Vehicles, Inc. for the name of the nearest dealer.*

I'm *COMUTA-CAR*

I've got the solution for stopping pollution.
Help fight inflation! Stay out of the station!
Drive with a smile for a few cents a mile.
Not going far? Drive COMUTA-CAR!

Call: 367-7473

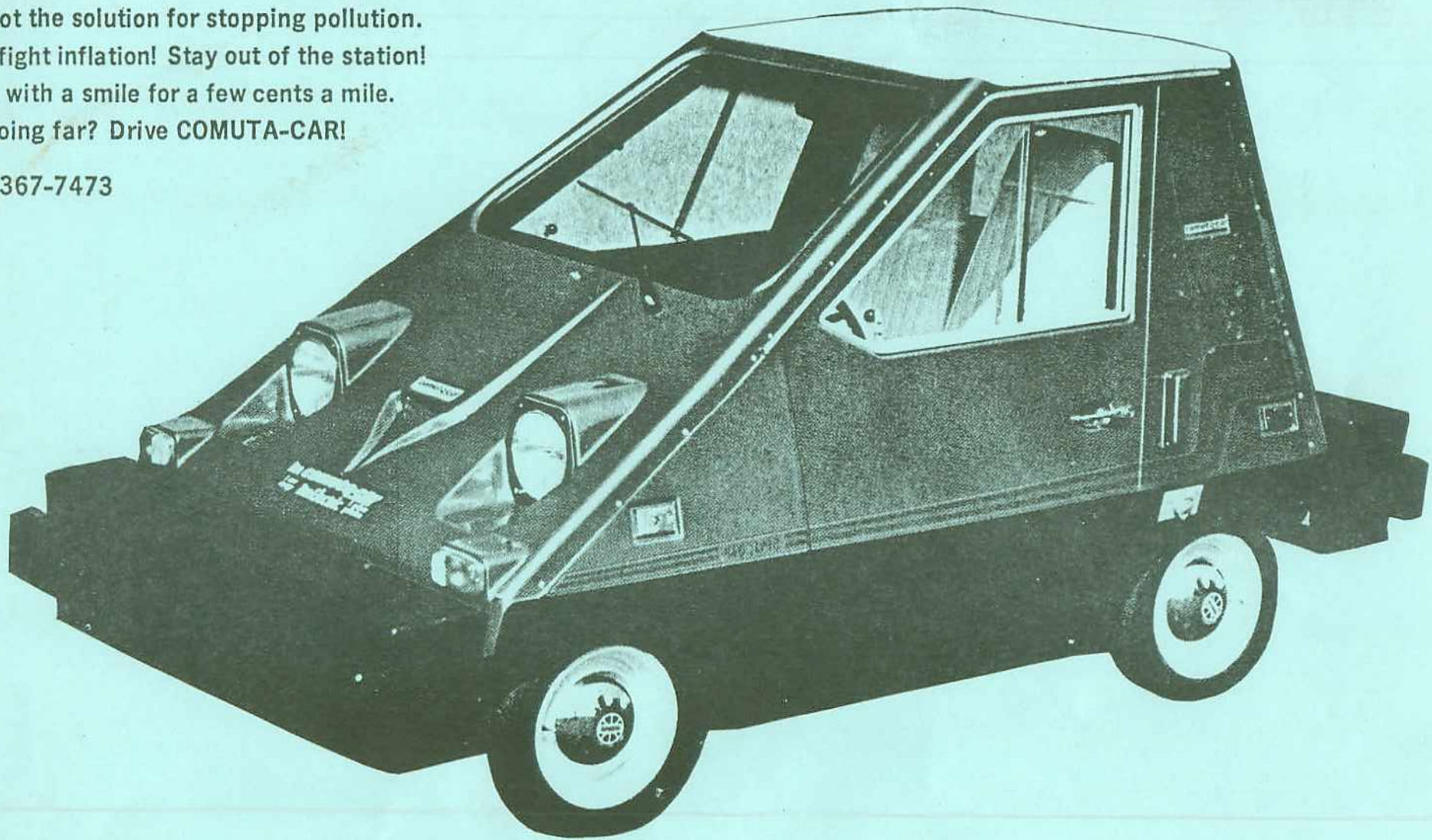

I save
energy

I'm Electric

I reduce
pollution

I'm *comuta-car*

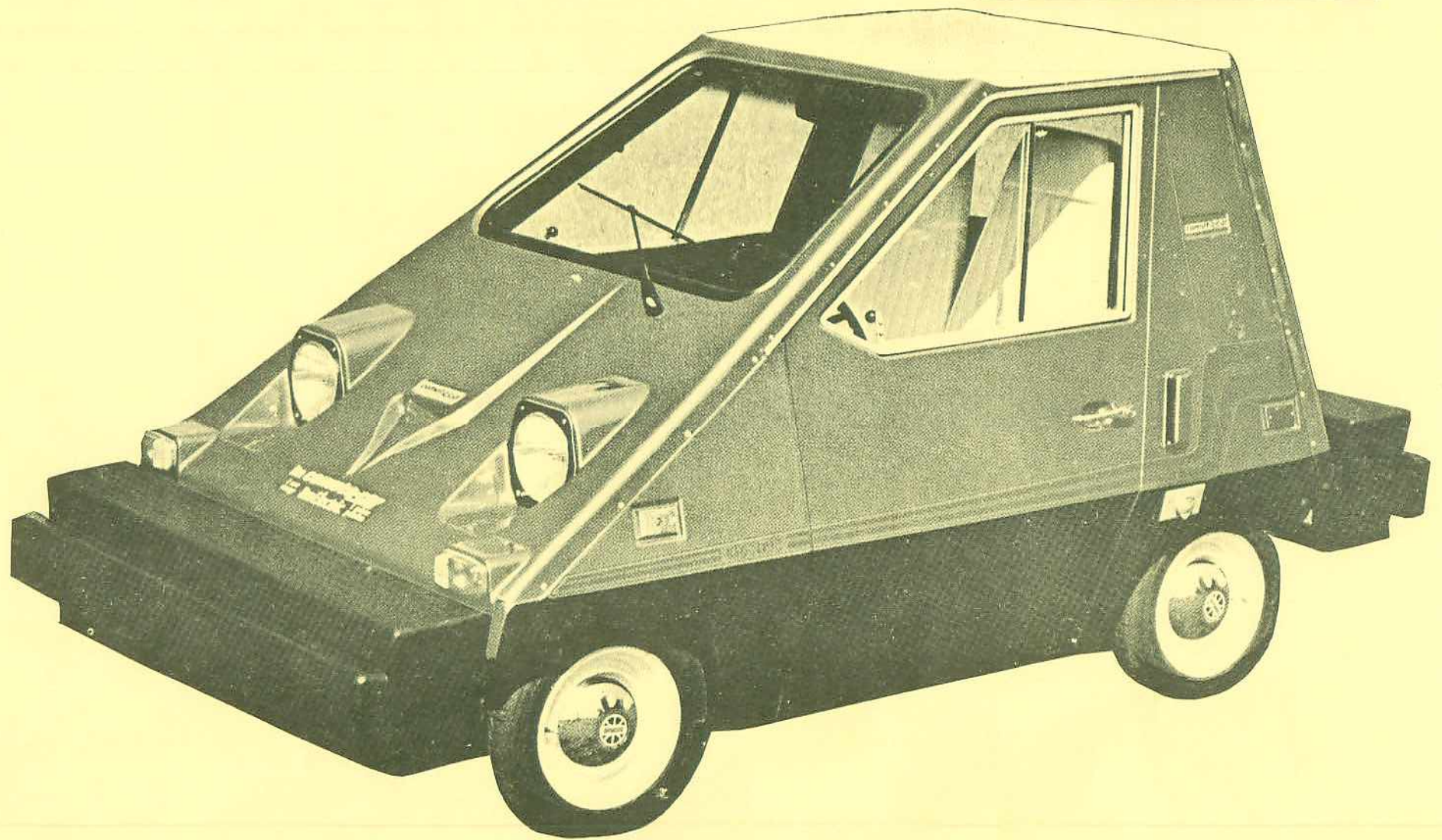

I save
energy

I'm Electric

I reduce
pollution